

Wireless Wearable Electrocardiogram (WWECG)

Group 9

Ulbert Botero

Ryan Shifman

Alexander Consunji

Karson Kimbrel

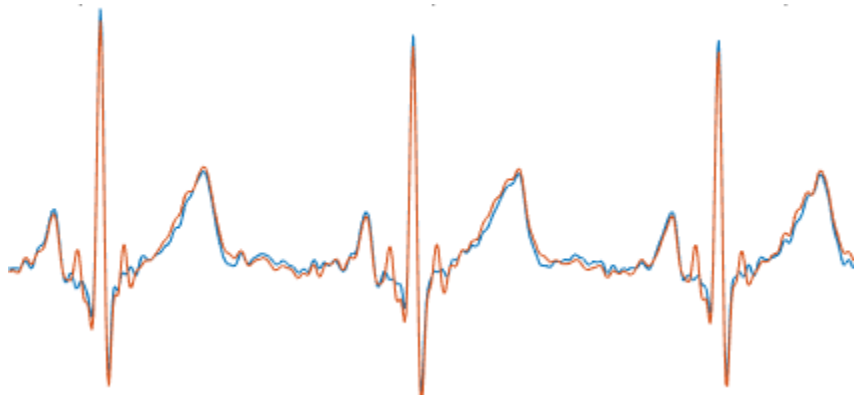

Contents

1 Executive Summary.....	7
2 Project Description	8
2.1 Project Overview	8
2.2 Goals and Objectives	9
2.3 Requirements.....	10
2.3.1 Physical Requirements	10
2.3.2 Functional Requirements	11
2.4 Realistic Design Constraints	12
2.4.1 Economic	12
2.4.2 Time	12
2.4.3 Ethical	12
2.4.4 Health and Safety.....	13
2.5 Project Operation	13
3 Research	13
3.1 Project Motivations.....	13
3.1.1 Previous Implementations.....	14
3.2 Electrocardiography	15
3.2.1 ECG Overview	15
3.2.2 Clinical ECG.....	17
3.2.3 The QRS Complex:.....	20
3.2.4 Driven Right Leg Circuit	21
3.2.5 Defibrillator Protection.....	22
3.2.6 Arrhythmias:.....	24
3.3 Sampling and Quantization Theory	29
3.3.1 Sampling in Time	29
3.3.2 Aliasing	30
3.3.3 Quantization:.....	30
3.3.4 Oversampling:.....	31
3.3.5 Noise Shaping:.....	32
3.4 Wireless Communications.....	32
3.4.1 Transmission Standard Comparison	32

3.4.2 Bluetooth LE 4.0 Overview.....	33
3.4.3 Local Bluetooth LE Network.....	33
3.4.3 Processing	35
3.4.4 Bluetooth Module Settings	35
3.5 Biomedical Signal Processing	36
3.5.1 Biomedical Signal Processing Applications.....	36
3.6 Electrodes	37
3.7 Signal Conditioning	38
3.7.1 Noise Sources:.....	38
3.7.1 Filtering/Noise Reduction:	39
3.7.2 Amplification:.....	39
3.8 Power Management	40
3.8.1 Rechargeable Battery Technologies	40
3.8.2 Charging Circuitry	40
3.8.3 DC-DC Converters	41
3.9 Data Converters	42
3.9.1 A/D Converters	42
3.9.2 D/A Converters	44
4 Standards and Constraints	45
4.1 Government Regulations.....	45
4.1.2 Radio Frequency Devices FCC.....	45
4.2 Bluetooth LE Hardware Constraints	45
4.2.1 Range	46
4.2.2 Transmitters needed for each Device	46
4.2.3 Latency	46
4.2.4 Data Rate.....	46
4.3 Bluetooth Software Security Standards.....	46
4.4 Testing Constraints	47
5 Design Plan	47
5.1 Electrode to Electrode Sampling Synchronization.....	50
5.1.1 Timestamping	51
5.3 Firmware and Software Plan	52

5.3.1 Electrode Sensors.....	53
5.3.2 Hub	55
5.3.3 Android Application	56
5.4 Hub Receiver and External Processing.....	59
5.4.1 Post-Transmission Preprocessing	59
5.4.2 Digital Signal Processing Algorithms for ECG signal	59
5.5 ECG Signal Requirements	64
5.6.1 Leads	64
5.6.2 Bandwidth	65
5.6.3 Gain	66
5.6.4 Resolution	67
5.6.5 Common Mode Rejection Ratio	68
5.7 Signal Acquisition Stage.....	68
5.7.1 Anti-Aliasing.....	68
5.7.2 Noise Filtering	71
5.7.3 Amplification.....	73
6 Parts and Hardware.....	75
6.1 Operational Amplifiers	75
6.1.1 Pin Configuration.....	75
6.2 DC-DC Converters	76
6.2.1 Pin Configuration.....	76
6.3 Texas Instruments TMS320C5535 DSP	77
6.3.1 Central Processing Unit	77
6.3.2 Internal Memory	77
6.4 Instrumentation Amplifier.....	78
6.4.1 Texas Instruments INA333.....	78
6.5 Bluetooth Module HM-11 with a Texas Instruments CC2541	80
6.6 Data Converters	80
6.6.1 Analog to Digital Converter	80
6.7 Digital to Analog Converter	84
6.7.1 Texas Instruments MCP4725:.....	84
6.8 Microcontrollers	86

6.8.1 Wrist Mounted Microcontrollers.....	87
6.8.2 Central Hub Microcontroller	88
7 Software Applications and Database.....	90
7.1 WVECG Server Specifications	90
7.1.1 The Database	91
7.1.2 The Application Programming Interface	95
7.3 WVECG Client Specifications.....	112
7.3.1 Screens.....	113
7.3.2 Custom UI Components.....	118
7.3.3 WVECG Bluetooth Link.....	119
7.3.4 WVECG Server Link	119
7.3.5 WVECG Live Processing	120
7.4 Storage.....	Error! Bookmark not defined.
8 Administrative Information	120
8.1 Project Management Methodology	120
8.2 Material Cost Analysis.....	121
8.3 Facilities and Equipment	121
8.4 Personnel.....	122
8.5 Past Activity Levels	123
8.6 Future Milestone Chart.....	128
9 Construction and Testing.....	130
9.1 Chipset Integration	130
9.2 PCB Design.....	131
9.3 PCB Manufacturing	131
9.4 ECG Signal Quality	132
9.5 Level of Comfort.....	132
9.6 Testing Procedures	132
9.6.1 Hardware Testing.....	133
9.6.2 Software Testing.....	133
10 Conclusion.....	134
11 APPENDIX A- Copyright Permission.....	135
12 APPENDIX B- References.....	136

13 APPENDIX C- Data Sheets and User Guides 138

1 Executive Summary

The ECG (Electrocardiogram) has been an invaluable tool to healthcare professionals since the early 1900s. Since its inception, many advances in technology have taken what was once a bulky laboratory instrument and turned it into the compact portable piece of equipment we know today. Our design project will further advance the ECG into a wireless wearable device for personal and professional health care use.

Today we find that the need for digital data to be easily accessible is a growing demand in the medical field. Our design will allow the user to act in a dynamic environment without the same constrictions as a conventional leaded ECG. The wireless transmission of data from our device will free the user to move about without the hindrance of wired leads from the ECG. This will also provide the healthcare professional the convenience of monitoring a patient's health without the need of being in the same room.

The WVECG (Wireless Wearable ECG) will use medical grade disposable electrodes that snap onto the device to pick up the electrical potential changes of the skin caused by heart's cardiac cycle. This signal will be riddled with noise so before it can be of any use it must be filtered to drown out any unwanted signals. We have decided that a combination of both analog and digital filtration will provide us a signal with the best fidelity. By using a series of analog filters the signal will be conditioned to drown out noise produced by mains hum (a 60 Hz electrical noise coming from power lines), motion artifact noise, and baseline drift. Once this signal has been digitized, a digital signal processor will use separate algorithms to adjust the signal shape, QRS wave, calculate heart rate, and detect ventricular arrhythmia.

The user will access this data through an app on their phone or tablet that will connect with our system using Bluetooth. The app will be developed for Android devices and will display the data gathered by our system to the screen of the device. The signal will be available to display in real time and the app will also keep a record of signals for a select period of time. Several modes of operation will be available such as a display of the ECG signal along with user heart rate. The app will provide an easy to use experience for the user whether they are a healthcare professional or a patient.

To develop this type of design it is necessary to research current and previous techniques used in both modern and outdated ECGs to understand what areas have been improved upon and what areas still need improvement. Consulting medical professionals and engineers with experience in the biomedical engineering field will be necessary in achieving the highest accuracy for our design. In creating a precise and accurate device to record heart activity we hope to expand the use of the ECG to broader fields as well. Our intent is to make the

WWECCG an integral part of tracking trends by providing the most accurate data possible for the user.

2 Project Description

With new innovative healthcare devices being integrated into the professional healthcare environment every year, the methods that doctors use to monitor patient's vitals are continuously changing. As medical equipment moves towards preventative healthcare the need for smaller and portable handheld devices increases. The WWECCG will provide the solution for these needs by reducing size and increasing accuracy with low power consumption communications and a mix of analog and digital processing. Advances in fabrication of chip size will be our biggest advantage in developing a smaller more compact diagnostic device than we have seen in the market.

Our design will take the analog signal from the body and convert it into digital data to be sent wirelessly over Bluetooth to be processed by an external processing unit. This processing unit will then send that processed data wirelessly over Bluetooth to an Android based mobile app that can be accessed through any Android device. The app will provide the user with an easily accessible display of their ECG signal.

2.1 Project Overview

Figure 2.1 below shows the block diagram that our system will follow. The signal will be obtained from two electrodes placed on the body and will then be filtered through a low pass filter with a 3 dB cutoff of 100 Hz for diagnostic purposes and a high pass filter with a 3 dB cutoff of .5 Hz to remove the noise caused by motion artifacts. A notch filter will remove the 60 Hz noise of the signal contributed by power lines. The amplification stages for each signal path will consist of operational amplifiers with gain stages adding up to a total gain of 1000. Such high gain is necessary for the signal to be converted to digital data as the initial signal obtained from the body is in the range of millivolts while the analog to digital converter's input range is read in volts.

The conversion of analog to digital data will allow the signal to be sent wirelessly by a low power Bluetooth module to be processed by an external processing unit. The external processing unit will utilize a digital signal processor to further condition the signal using algorithms to reduce noise and improve signal shape, detect ventricular arrhythmia, and identify QRS complexes. The android and web app portion will deal with the recording and display of user data.

The WWECCG system will utilize lithium ion technology to make it a portable and rechargeable product. Advancements in lithium ion polymer technology have

reduced the size of rechargeable battery packs allowing for the reduction of the charge management portion of our design. This reduction in size will greatly contribute in our attempt to keep our system small and wearable while still having the capability of being rechargeable, thus eliminating the waste of having to recycle conventional batteries.

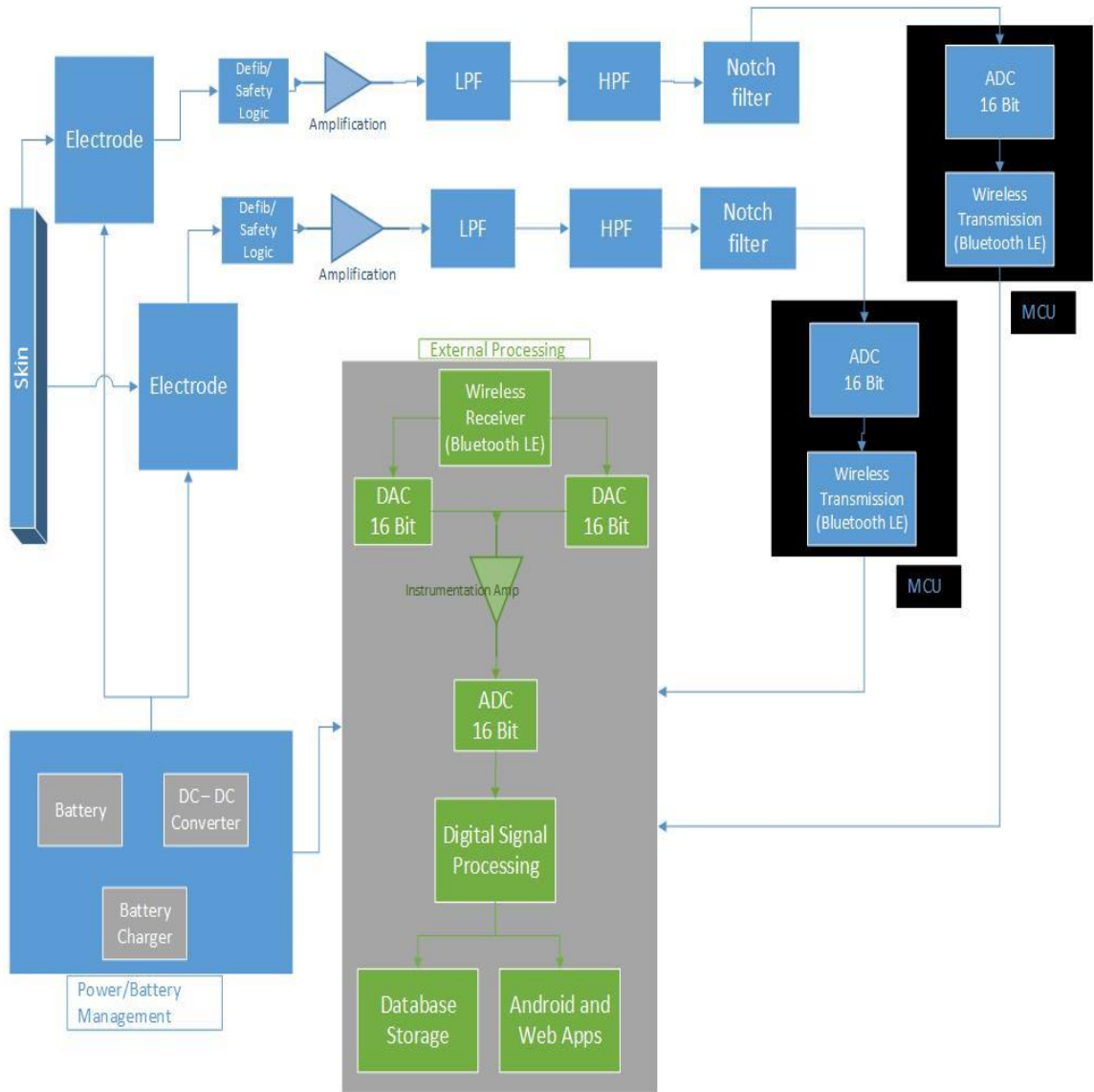

Figure 2.1 – System Block Diagram

2.2 Goals and Objectives

The overall objective of this project is to create a fully functional ECG completely wirelessly, while there have been many ECGs on the market that utilize newer

wireless technologies like Bluetooth and Wi-Fi, there is currently no market implementation of a completely wireless that features two electrode sensors that are not connected together with physical wires. Our current design aspirations feature this by transmitting all necessary data with Bluetooth in order to fix this problem. By having two separate electrodes it allow whomever the current user is to move both arms freely by using wrist mounted sensors. Overall while constructing this project the following goals the project looks to output is the following,

1. A completely hands-free wrist mounted implementation of a rhythm strip that would normally be produced by an Electrocardiogram.
2. An active mobile application that stores and displays the user's data for them to interpret and utilize as needed.
3. Run for an extended period of time of at least an hour.
4. Have a simple and easy to use interface system in regards to both software and hardware.
5. Make the device comfortable enough to wear allowing the user a completely hands free range of motion.
6. Display a high resolution image of the user's data in graphical format similar to a professionally made ECG.
7. Notify the user of any possible problem that may be occurring within the heart arrhythmia, atrial fibrillation etc.

By meeting all of these goals, the WWECG will be one of the first full wireless implementations of an Electrocardiogram, and will be able to help detect various heart problems that can only be detected by a standard ECG.

2.3 Requirements

A total combination of all the subset requirements listed below will result in the overall needs for the project above. In order to meet the project goals seen above, these requirements need to be met fully and in conjunctions.

2.3.1 Physical Requirements

For the WWECG the overall physical requirements that need to be met in order to meet the project goals can be seen below within **Table 2.3.1**. As show in the table these requirements help determine the physical limits and capabilities of the WWECG while also working around the hardware constraints imposed.

Dimensions	50mm x 50mm x 15mm (LxWxH) for the wrist mounted electrodes. 200mm x 100mm x20mm (LxWxH) for the hub for data transmission.	
Power and Transmitter Runtimes	Lithium-Ion polymer with Micro USB Charging	1 Hour Runtime
Weights	Each Electrode with transmitters 16gs	
Operating Conditions	10-40C	25-75% humidity
Storage Conditions	-20 - 50C	25-75% humidity
ECG Channels	1 Channel	
Frequency	.5 to 100hz	
Sampling rate	500 samples per second	
Sampling Resolution	16 Bit	

Table 2.3.1 –Physical Requirements

2.3.2 Functional Requirements

The table below in **Table 2.3.2** displays the overall functional requirements that need to be completed in order to achieve a proper method of performance throughout the WWECG.

Physical Functionality	-Simple clean physical interface that allows user easy access to all necessary points as well as notification LEDs. -Device should be sleek and comfortable when worn for at least an hour.
Software Interface	-Visual Display showing the full rhythm strip. -Simple user menu and access in order to view past readings. -Able to store data from multiple sessions of readings to serve and compare data from remote server to current reading. -Detection for ECG recognizable heart symptoms. -Must comply with HIPAA requirements.
Server Interface	-Ability to store and access data upon user requests. -Must comply with HIPAA requirements.

Table 2.3.2 –Functional Requirements

2.4 Realistic Design Constraints

The current design constraints for the project are due to the following sections below, Economic, Time, Ethical, Health and Safety constraints. Due to these subjects the capabilities of this project will be limited to a proof of design concept that could possibly be used in commercial application.

2.4.1 Economic

The main economic constraint within this product revolves around the fact that it is currently without any forms of sponsorship which limits the amount of testing mechanisms available to use for testing and parts. With the need for the highest quality parts possible while also maintaining within the current budget of four full time students being a key factor in our choice of parts as well as our testing material, the current economical state is a large contributing factor to the product accuracy. With this product accuracy needing to only meet commercial standards rather than medical, the project is still capable of being produced by sacrificing some unnecessary features that would add cost to the project.

2.4.2 Time

Another extremely large factoring into the design and implementation of the project regards the limited amount of time available for each member of the group. With all of the members of the group having other tasks and commitments throughout the projects construction, the given amount of time limits the amount of features that the project will be capable of. While the WWECG will still have all of its overall base hardware aspects, to mimic a full ECG in a medical testing sense would require not only multiple months to years of testing on top of our previous design, but also would require many more electrodes that would add another layer of complexity to the project in both design and simulation. With a fully functional ECG consisting of at least 12 nodes attached to the body at a given time to be used for medicinal purposes, the capabilities of our project creating and having a properly functioning device would be extremely unlikely given the current time constraints of the project.

2.4.3 Ethical

The key ethical constrain when developing this project is during the testing for the device without using people or animals. In order to overcome this problem, testing will be done using an ECG simulator which will allow for unlimited testing without violating a domestic or international human testing standards since the entirety of human testing will be ignored.

2.4.4 Health and Safety

For this project the key constraints with the health and safety regard safely allowing the user of the device to use it for an extended period of time comfortably without there being electrocuted while wearing the WWECG. Another concern regarding the health and safety is to not burn the user in case of defibrillator use while wearing the device. So when developing the device these two constraints need to be kept in mind. Another important constraint is the need for encrypted data whenever it is transmitted from device to device in order to protect the user's data from outside unwanted access.

2.5 Project Operation

The Wireless Wearable Electrocardiogram is a wearable health-monitoring device that will provide its user with an accurate display of heart activity, heart rate, and warn of arrhythmia detections. All of this information will be displayed to the user via an android mobile application. The WWECG consists of two wrist sensors that serve to calculate Lead 1 for heart activity. First you attach the electrode clip to a location on the user's body. For this example the wrist is commonly used as the location of each electrode. Each sensor then acquires the biopotential signal and conditions it to be digitized and transmitted wirelessly via Bluetooth LE to the Hub. The Hub is both a docking/recharging station for the sensors and serves to complete the processing of the signal. Specifically, the Bluetooth LE transmitted signals are received at the hub and then passed into an instrumentation amplifier to produce the desired electrocardiogram signal. This signal is then converted to digital and further cleaned up in the digital signal processor. Additionally, it is here where the algorithms to detect the QRS complex of the waveform, the user's heart rate, and detection of any arrhythmias are implemented. The data will be transmitted continuously while the hub is in operation and the user's mobile application is connected to the hub via Bluetooth. Now the user will open the application on their mobile device and log into their created account. Once logged in they can view a real time display of their heart rhythm activity, with markings of where the QRS complex is occurring, along with a display of their heart rate. Furthermore, this application will notify the user if any arrhythmic behavior has been detected.

3 Research

This section discusses our research findings that guided our design approach.

3.1 Project Motivations

Overall the group motivation for this project comes down to a desire to learn more about signal processing, biomedical engineering uses electronics, wireless

transmission data transfers and client server applications using an Android device and communicating with a separate hardware entity from a singular application. The main motivation for moving towards a more biomedical engineering in combination with our already more well versed fields of study is the desire to familiarize ourselves with the field's various aspects that vary and are similar to what we have learned throughout our undergraduate careers. The main reason that the project was decided to move towards an ECG was due to not only interest in cardiology itself, but it also provides valuable knowledge on how to take readings from wrists mounted devices which is currently popular with fitness companies. Feeling that these experiences could give us an edge when entering the workforce while also desiring to work towards a newer more innovative project, it was determined that a wireless wearable device would be best suited for a Senior Design project.

3.1.1 Previous Implementations

While researching various implementations of ECGs and wireless transmitters, a few different wireless ECG models were discovered featuring designs similar to WWECG but still maintaining an underlying wiring to determine the timing difference between both electrode sensors.

3.1.1.1 MIT Thesis

During our overall design and planning stages of the project was a Master's thesis paper by Margaret Delano from MIT proved to be one of the best references possible. Developing a wearable Electrocardiogram monitor, there was not only a concise and accurate representation of her design and implementation, but also an extremely descriptive and accurate representation of ECGs and their uses from an electrical engineering perspective. Providing many helpful resources of commercial implementations that have already been done, there were also many helpful descriptions about various implementations that were not originally considered within our design plan. Providing the complete overview from design to implementation along with the various errors encountered when designing and creating the project, the document also will allow us to recover from many challenges that would have likely occurred during this WWECG implementation. Overall this this proved to be an extremely helpful document during each stage that have been completed so far as well as the development plans in the future.

3.1.1.2 Qardio

Another one of the current implementation of a wearable ECG on the market is called the Qardio™. It features a four electrode module that is mounted on the chest rather than the wrists and uses dry electrodes as well rather than wet. Similar

to other designs that have already been developed this implementation hides the wiring between electrodes instead of having a completely wireless implementation.

3.2 Electrocardiography

Before implementing any signal processing algorithms to describe and detect heart behavior it is important to understand what it means. Therefore, it is necessary to first gain an understanding of the heart and body's operation as an electrical system. The heart is made up of the myocardium muscle that rhythmically contracts and drives circulation of blood throughout the human body. Before every heartbeat an electrical current is passes through the entire heart and triggers myocardial contraction. This event is referred to as a systole. The electrical waves propagate over the structure of the heart in a coordinated pattern that leads to a coordinated systole. This allows for a measurable change in potential difference across the surface of the body. This potential difference can then be amplified and filtered to produce the popular electrocardiogram signal known today. The ECG signal has a wide range of factors that can affect its behavior. These include abnormalities in the cardiac conducting fibers, metabolic abnormalities of the myocardium, and macroscopic abnormalities of the heart's geometry.

3.2.1 ECG Overview

The next two sections give a brief overview of the main processes that occur within the ECG.

3.2.1.1 ECG Cellular Processes

Every heartbeat is triggered by an action potential that originates from a rhythmic pacemaker in the heart which produces a coordinated contraction after being conducted rapidly throughout the organ. The myocardial cell typically has a resting membrane potential, V_m , of approximately -80 to -90 mV with respect to its surrounding extracellular fluids. The cell membrane controls the permeability of different ions such as, sodium, potassium, calcium, and chloride. This permeability is responsible for the ions being able to pass across the membrane via opened and closed ion channels. Furthermore, these gated channels open and close as a response to voltage changes in the voltage gated channels or the activation of receptor gated channels. The variation of conductance in the membrane due to the opening and closing of the ion channels generates changes in the action potential. There are five conventional phases that the cell goes through during depolarization and repolarization. First, the cardiac cells are depolarized to the threshold voltage of -70mV. Phase 0 to phase 1 consists of the depolarization caused by a transient increase in fast sodium channel conductance. Then phase 1 is the repolarization of the cell caused by the opening of the potassium channel.

At phase 2 there is now a balance between the incoming calcium current and outgoing potassium current that causes a plateau in the action potential and delay in repolarization. Repolarization then occurs in phase 3 due to an increase in potassium conductance. Additionally, repolarization occurs because a decrease in calcium conductivity occurring at the same time. The last phase (phase 4) acts as the resting phase and consists of open potassium ion channels and a negative membrane potential.

Cardiac cells that possess the property of automaticity, known as pacemakers, are critical to action potential propagation. They have the ability to spontaneously depolarize and this property allows them to behave as pacemakers for the rest of the heart. These cells are found in the sino-atrial node, atrio-ventricular node, and in some specialized conduction systems within the atria and ventricles. In automatic cells, the resting potential is not stable and shows spontaneous depolarization. Once the cell's potential reaches a threshold level the cell then develops an action potential that is mediated by calcium exchange at a very slow rate. After the action potential the cell then returns back to its resting phase and the cycle repeats. There are graded levels of automaticity of the heart that are directly related to heart rate. For example, the SA node's (sino-atrial) rate is the highest around 60-100 beats per minute, followed by the AV(atrio-ventricular) at approximately 40-50 bpm, and then the ventricular muscle at about 20-40 bpm.

Once an action potential is initiated in a cardiac cell it will continue to propagate throughout the cell until the entire cell is depolarized. The action potential is spread throughout the myocardial cells due to their unique ability to transmit action potentials from cell to adjacent cells via direct current spread. The cell membranes are tightly coupled and this allows them to transmit the tension and electric current from cell to cell. Furthermore, the ionic currents flow from cell to cell via low resistance gap junctions and this allows the heart to behave electrically as a syncytium. Therefore, an impulse that originates anywhere in the myocardium will propagate through the heart and produce a coordinated mechanical contraction. In addition to the action potential propagating via the myocardium, it can also propagate via bands of specialized conducting fibers. By traveling across combinations of both methods the action potential is able to propagate to all the regions of the ventricles.

3.2.1.2 Physical Basis behind ECG

We are able to measure the potential differences on the skin's surface and current that flows within the body due to the electrical activity of the cells. The graphical representation of these potentials plotted as a function of time are the popularly known Electrocardiogram. The most popular mathematical model used to relate the body surface potentials to the electrocardiogram signal is the single dipole model. This model has two main components, the dipole that acts as a

representation of the heart's electrical activity, and the geometric and electrical properties of the surrounding body. First, the electrical activity of the heart is considered. As an action potential propagates throughout a cell it generates an intracellular current as well in that same direction. This is the basic source of the surface electrocardiogram and is referred to as the current dipole. In contrast, there is an equal extracellular current that flows in the opposite direction or propagation that conserves charge. These current loops close upon themselves and form a dipole field.

The net equivalent dipole moment is referred to as the time-dependent heart vector $M(t)$. This is based on the assumption that if the heart were observed in a homogenous isotropic conducting medium at a distance large compared to its size, then all the current dipoles can be assumed to originate at a single point. Then the total electrical activity in the heart can be depicted as a single equivalent dipole whose magnitude and direction is the vector total of all the smaller poles. The heart vector changes with respect to magnitude and direction as each wave of depolarization occurs. The current and potential distributions depend on the electrical properties of the torso and approximating the dipole model as a linear, isotropic, homogenous, spherical conductor with radius, R , and conductivity, σ . The static electrical field, current density, and electrical potential all along the torso are related to the heart vector as a quasi-static model. Based on the assumptions above the potential distribution of the torso can be represented by

$$\varphi(t) = \frac{\cos\theta(t)3|M(t)|}{4\pi\sigma R^2}$$

where $\theta(t)$ represents the angle between the direction of the heart vector $M(t)$ and the lead vector, OA . OA represents the center of the sphere, O , joined to the point that is being observed, A . The potential difference between two points on the surface can be generally related by the equation

$$V_{AB}(t) = M(t) * L_{AB}(t)$$

and L_{AB} is the lead vector on the torso connecting points A and B . Lastly, a central terminal (CT) is determined by averaging the potentials across the three limb leads, right arm (RA), left arm (LA), and left leg (LL). This central terminal acts as a reference and should be zero at all times.

$$\varphi_{CT}(t) = \varphi_{RA}(t) + \varphi_{LA}(t) + \varphi_{LL}(t)$$

3.2.2 Clinical ECG

The clinical ECG is based on a number of factors but mainly on the contraction and relaxation properties of the myocardium. The heart has four cavity chambers with walls that consist of mechanical syncytium of myocardial cells. There is a valve that closes after each contraction at the exit of each chamber. This serves to

prevent retrograde flow while the chamber relaxes and the downstream pressure exceeds the pressure within the chambers. The right heart has a small atrium that leads into a larger right ventricle. This right atrium receives blood from the body and flows it into this right ventricle. The right ventricle then contracts to push the blood into the lungs, where it is oxygenated and carbon dioxide is removed. The left atrium behaves similarly by conducting blood into the left ventricle but instead of propelling the blood into the lungs it pushes it through the aorta to the rest of the body.

Additionally, there are nine different temporal states that relate to the trajectory of heart vectors. Atrial depolarization is when the wave of depolarization flows throughout both atria and the summation vector is pointing down, to the subject's left, and anterior. The next state involves the delay at the AV node. During this delay there is no electrical activity that can be measured as a surface potential unless special techniques are used. Afterwards, activity emerges from the AV node and depolarizes the His bundle and the bundle branches directly after. Next is septal depolarization. During this state as the action potential enters the septal myocardium the wave propagates from left to right and the resulting heart vector points to the subject's right. Apical depolarization is when the wave of depolarization moving left is balanced by the wave moving right. This results in the heart vector pointing towards the apex of the heart. Left ventricular depolarization and late left depolarization both consist of electrical activity in the right ventricle but the activity in the left ventricle dominates. Once the various portions of the myocardium depolarize, they begin the excitation-contraction process. Then there is a period where the myocardium depolarizes and no action potential propagates, which results in no measurable cardiac vector at this point. Finally, the cells begin to repolarize and a wave of charge passes through the heart. This charge originates from depolarizing and repolarizing tissues. Afterwards, the heart returns to a resting state and awaits another electrical stimulus to restart the cycle.

Lastly, the clinical ECG is based on the cardiac vector, which expands, contracts, and rotates in three dimensional space, and is projected onto 12 different well defined directions. These 12 orientations are the basis behind the common 12 lead configuration. Each lead represents the magnitude of the cardiac vector in that direction at each instant in time. Typically, there are six leads placed around the torso and the ECG signal will represent the difference between the specific leads and the central terminal discussed earlier. Furthermore, there are four additional limb leads attached to the patient. The potential differences between the combinations of limb leads results in the remaining clinical ECG leads. Lead 1 is the potential difference between the left arm and right arm. Lead 2 is the potential difference between the left leg and right arm. And the potential difference between the left leg and left arm results in lead 3. These leads are often referred to as the Einthoven Limb leads (bipolar).

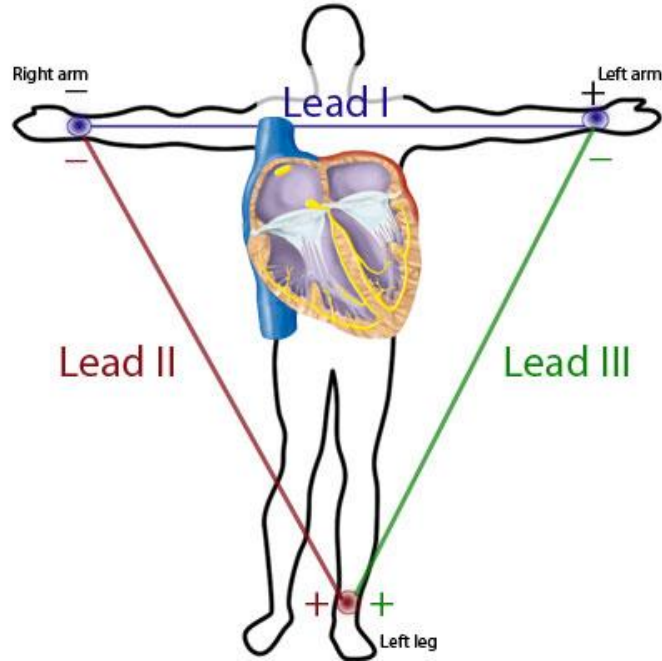

Figure 3.2.2: Einthoven's Triangle

$$\text{Lead 1: } V_1 = \varphi_{LA} - \varphi_{RA}$$

$$\text{Lead 2: } V_2 = \varphi_{LL} - \varphi_{RA}$$

$$\text{Lead 3: } V_3 = \varphi_{LL} - \varphi_{LA}$$

The right leg is typically used as a ground reference electrode in most clinical electrocardiograms. Additionally, the three limb leads are typically sufficient for determining the heart's rhythm. In addition to the Einthoven limb leads the augmented limb leads can represent the potential at a given limb with respect to the average of the other two limb's potentials. Augmented limb leads are denoted by "a", such as aVR, which is the difference to between the right arm and the average of the left arm and left leg leads. The other augmented leads are aVF, difference between left leg and average of right arm and left arm, and aVL, the difference between the left arm and average of the right arm and left leg potentials. Due to using twelve leads to image three dimensional space some information may be redundant but this is still helpful for aiding in human interpretation of the heart's behavior as well as helping to account for minor errors in electrode placements. This is often referred to as spatial oversampling.

3.2.3 The QRS Complex:

The QRS complex refers to the combination of three of the most prominent deflections seen on the ECG. It typically corresponds to when the right and left ventricles of the heart are in the depolarization state. The clinical significance of the QRS complex is that it provides a useful method of diagnosing cardiac arrhythmias, conduction abnormalities, ventricular hypertrophy, and other types of disease states. For example, a conduction abnormality would be able to be seen directly because it would widen the QRS complex. In addition, the QRS complex is typically used to determine the electrocardiogram's axis. Commonly, the ECG has five deflections that correspond to the P, Q, R, S, and T components of the ECG signal. A Q wave is any downward deflection that occurs after the P wave. An R wave then follows this Q wave but as an upward deflection instead. And the S wave is the following downward deflection following the R wave. The Q wave represents the depolarization of the interventricular septum, which is the wall that separates the lower chambers of the heart from one another. When the electrical signal passes through a scarred heart muscle it is referred to as a pathologic Q wave. Pathologic Q waves are typically used as markers for previous myocardial infarctions (heart attacks). The R wave is represented differently depending on the lead it is measured from. With respect to lead V_1 the rS complex typically shows an increasing R and decreasing S when moving towards the left. In leads V_5 and V_6 the R-wave amplitude is taller in V_5 than V_6 . The transition zone occurs in leads V_3 or V_4 . During this period the QRS complex changes from being mostly negative to being predominantly positive. It isn't uncommon for this transition zone to also appear earlier at V_2 or later at V_5 . The R wave is an important indicator in signal processing and biomedical engineering. In biomedical engineering the maximum amplitude of the R wave is often referred to as the R peak amplitude or just R peak. And the accurate detection of the R peak is essential in heart rate measurement and arrhythmia detection signal processing algorithms. Poor R wave progression is when the R wave is less than 2-4 mm in leads V_3 or V_4 and/or an occurrence of a reversed R wave progression, and it is commonly attributed to heart attacks as well. Lastly, the J-point is the location where the QRS complex meets the ST segment. It is typically the first point of inflection for the upstroke of the S wave and where the ECG trace becomes more horizontal than vertical.

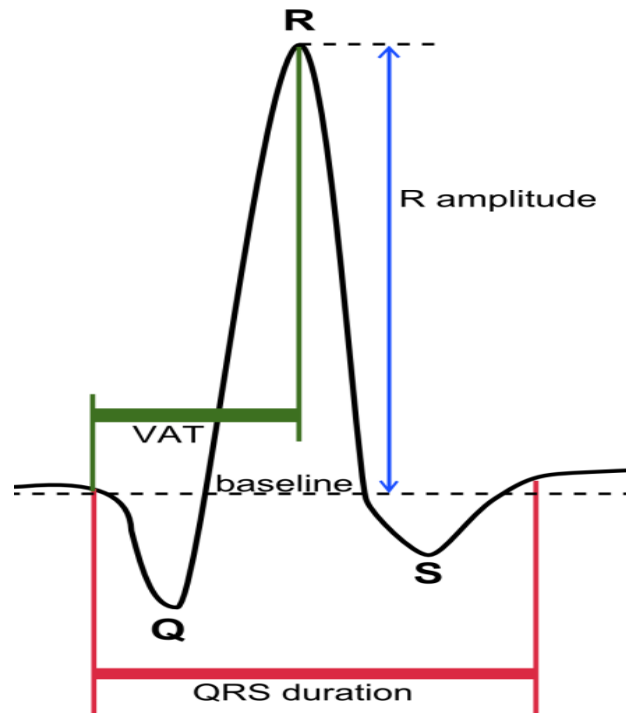

Figure 3.2.3. : Typical QRS complex in Electrocardiogram Signal

3.2.4 Driven Right Leg Circuit

The driven right leg circuit is a common circuit employed in electrocardiograms and other biological signal amplifiers. Its main purpose is to aid in reducing the common-mode noise often seen at electrode inputs. The body often acts as an antenna which picks up electromagnetic interference, mainly the 50/60 Hz noise from electrical power lines. This noise tends to be a much higher amplitude than the desired biopotential signal which makes it much harder to measure those desired signals. Another common source of noise is the Common-mode to differential mode conversion. Due to mismatches in electrode impedances it's common that some common-mode voltage sneak into the differential voltage of the instrumentation amplifier. The driven right leg circuit aids in eliminating these noise issues by using the two typical limb leads, instrumentation amplifier, and a third driven electrode. The added circuitry measures the common mode voltage between the two electrodes and negatively amplifies the output. The body is then driven to that potential because it is tied to the circuit common. This effectively drives any power line noise back into the body as well. By driving these signals back into the body it is effectively minimizing the amplitude of these signals and makes it easier to measure the desired ECG signal. Additionally, this circuit helps increase patient safety. If a high voltage were to appear between the patient and ground then the auxiliary op amp attached to the patient on the right leg would saturate. This saturation causes the op amp to no longer be able to drive the right

leg and ungrounds the patient. A large resistor between the patient and ground, normally on the order of Mega ohms, is normally large enough to protect the user.

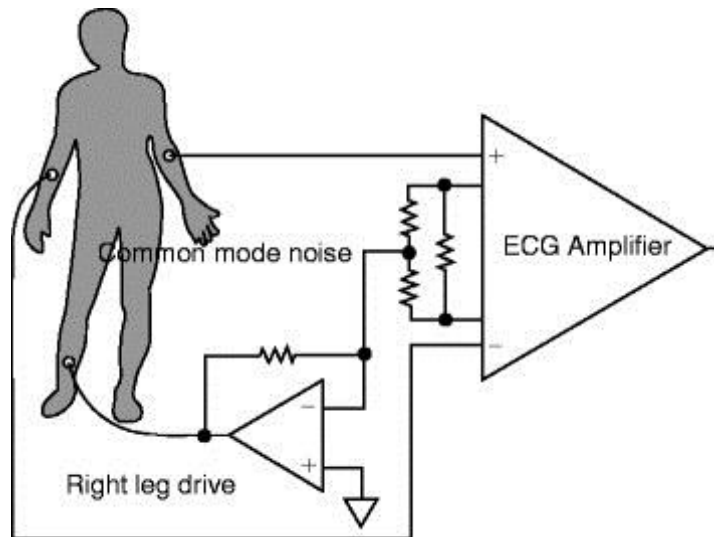

Figure 3.2.4 Right Leg Driven circuit - Permission Pending

3.2.5 Defibrillator Protection

The purpose of our wireless wearable electrocardiogram medical device is to provide a safe and convenient method of measuring the user's heart rhythms. Often the device itself will not provide any electrical risk to the user but there are instances that the opposite is true. Specifically, when a defibrillator is used on a patient it presents a risk to the electronics of the monitoring device due to the high voltage applied to the human body through the defibrillators. It is possible that the high voltage could be transferred from the leads attached to the patient into the ECG sensors. Therefore, the purpose of the defibrillation protection circuit is more to protect the electronics of the device from an abnormally high voltage pulse than the patient. It is most important for the circuit to limit the voltage and current that can be transmitted to the device. There are mainly two commonly implemented methods for voltage limiting, using voltage suppression diodes and gas lamps/gas discharge tubes. And series resistors are often employed to limit the current.

3.2.5.1 Transient-Voltage-Suppression

Transient-Voltage-Suppression diodes (TVS Diodes) are very useful electronic components that mainly serve to protect sensitive electronics from sudden voltage spikes. They operate by shunting excess current when the voltage surpasses the avalanche breakdown voltage of the device. Then clamping the voltage by suppressing all voltages that are greater than its breakdown voltage. Afterwards, once the abnormally large voltage has subsided the device automatically resets

and absorbs a large amount of the transient energy internally. TVS diodes can be either unidirectional or bidirectional. Unidirectional TVS diodes mainly act as forward direction rectifiers that can handle higher peak voltages than other avalanche diodes. Bidirectional TVS diodes typically are represented by two mutually opposing avalanche diodes that are in series with each other and connected in parallel to the circuit that they are protecting. An advantage of TVS diodes is that they are able to respond to over-voltages much faster than other typical voltage suppression components like varistors or gas discharge tubes. They tend to operate and clamp the voltages within 1 picosecond. However, there are three instances for which the TVS diodes will fail. A short in the circuit, open circuit, or a degraded device. If subjected to conditions that it wasn't designed to accommodate the TVS diode will most likely fail.

3.2.5.2 Gas Discharge Tubes:

Gas discharge tubes are another commonly implemented method of voltage suppression, especially in Electrocardiogram front end circuitry protection. Specifically, gas discharge tubes are an arrangement of electrodes in a gas that are within an insulating, temperature resistant envelope. These tubes exploit the behavior of electric discharge specific to when it is within a gas. They operate by discharging in the gas with an applied voltage that is enough to cause electrical conduction based on the principles of the Townsend discharge. Specifically, this process occurs when free electrons in a gas are accelerated by a strong electric field and leads to conduction within this gas by avalanche multiplication, similar to avalanche breakdown in TVS diodes. Once the number of free charges decreases or the incidental electric field weakens the process will cease. The voltage required to begin and hold the discharge of the gas tube depends on the composition and pressure of the gas within the tube, as well as the geometry of the tube. Different types of gases have different applications when implemented in gas discharge tubes. For the purpose of voltage regulation for electronics protection neon glow tubes are typically employed.

3.2.5.3 Electrostatic Discharge Protection:

Another potential risk to the electronic monitoring device is electrostatic discharge. Medical devices like the Wireless Wearable Electrocardiogram often have patients and medical professionals handling the device. This high amount of frequent contact presents the opportunity for a simple static discharge to enter the device and harm the electronics. To protect from ESD space-efficient semiconductor based devices such as Zener diodes are most often employed.

3.2.6 Arrhythmias:

A key feature of the wireless wearable electrocardiogram will be implementing an arrhythmia detection algorithm in the digital signal processing portion of the device. This is an important feature because it will allow for the user, whether it be a physician or someone using it for fitness tracking, to be warned once an arrhythmic breathing pattern has been detected. Before implementing such an algorithm it is important to understand what arrhythmias actually are and the different types of them.

An arrhythmia is any irregularity occurring in the patient's sinus rhythm. An arrhythmia is typically associated with electrical instability and abnormal mechanical cardiac behavior. Additionally, most arrhythmias are categorized by the locations the electrical abnormalities originate from. For example, atrial flutter is a type of arrhythmia that occurs in the atria of the heart. Arrhythmias can be diagnosed due to a variety of conditions. They can consist of isolated abnormal beats, sequences of abnormal beats mixed with regular beats, or exclusively abnormal beats. The severity of arrhythmias vary based on how much they interfere with the hearts normal activity. Isolated beats tend to not be worrisome because they don't interfere with normal cardiac behavior too much. However, it is an indication that there may be an underlying pathology in the cardiac tissue. Sinus rhythms that are predominantly abnormal are much more problematic. Most are easily handled with medication but others can be fatal if they aren't handled immediately.

Arrhythmias are mainly caused by non-pacing cells acting like pacemakers, and is known as reentry. Reentry is due to a conduction pathway loop that contains a region of blocked conduction and a region of slowed propagation. When the action potential reaches its point of origin it comes in contact with excitable tissue and causes an oscillation around the loop at least once. Reentry can occur in multiple locations within the heart, such as the atria or ventricles of the heart. In fact, it is important to distinguish between arrhythmias occurring in either region. Atrial arrhythmias rarely are severe or life threatening. They mainly result in minor issues such as palpitations, weariness, or decreased exercise tolerance. But ventricular arrhythmias very severe and life threatening if not handled immediately.

3.2.6.1 Types of Arrhythmias

There are multiple types of arrhythmias that vary greatly from one another. This section discusses a brief overview of their most prominent distinctions.

3.2.6.1.1 Atrial Flutter

Atrial flutter is caused by a reentrant rhythm that occurs in either the right or left atrium. An electrical impulse prematurely arises in the atria and the differences in tissue properties then cause a loop of reentry moving through the atrium. Atrial flutter is normally associated with an elevated heart rate of more than 100 beats per minute. Typically this condition occurs in individuals with cardiovascular diseases and diabetes mellitus, but it can occur in people with normal hearts as well. Although those cases tend to be more spontaneous and not long lasting. Rarely does atrial flutter persist for months to years. The main worry with atrial flutter is that it frequently degenerates into atrial fibrillation, which is a much more serious arrhythmia.

Electrocardiogram diagnosis of atrial flutter is characterized by flutter waves at a rate of 240 to 440 beats per minute. These flutter waves can be symmetrical, resembling p-waves, or be asymmetrical with a shape similar to a saw tooth signal. There are two types of atrial flutters. Type 1, which is commonly referred to as common atrial flutter, has an atrial rate of 240-340 beats per minute. And type 2 which has a faster heart rate of 340-440 beats per minute.

3.2.6.1.2 Atrial Fibrillation

Atrial fibrillation is characterized by rapid and irregular beatings of the hearts rhythm. It begins as brief periods of abnormal beatings, such as atrial flutter. Then the periods increase in length until they are the predominant sinus rhythm. Atrial fibrillation normally has no symptoms but occasionally signs of atrial fibrillation can be heart palpitations, fainting, shortness of breath, or chest pain. Furthermore, this condition can increase the likely hood of developing heart failure, dementia, or a stroke. Atrial fibrillation is typically diagnosed by using an ECG and characterized by a lack of P waves and an irregular ventricular rate in the ECG signal. To continue, atrial fibrillation is normally treated with medication that slows the heart rate close to a normal range or to convert the abnormal sinus rhythm to a normal one. Lastly, atrial fibrillation is the most common serious arrhythmia.

Typical electrocardiogram diagnosis of atrial fibrillation consists of the absence of P waves in the signal, as mentioned above, but also irregular R-R intervals. Although at really high heart rates atrial fibrillation can appear as a more regular sinus rhythm, which can create difficulties in diagnosis. Furthermore, an atrial fibrillation's QRS complex normally is a wider QRS complex than the narrow normal sinus rhythm QRS complex.

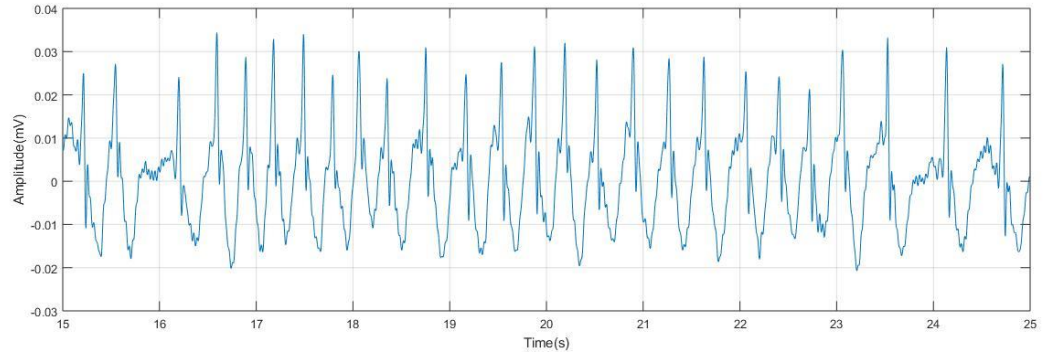

Figure 3.2.6.1.1: Atrial Fibrillation interspersed with Normal Sinus Rhythm

3.2.6.1.3 Ventricular Flutter

Ventricular flutter is an arrhythmia that has a fast rhythm of over 250-350 beats per minute. On an electrocardiogram its morphology is characterized by a sinusoidal shape that has no clear definition of the QRS complex or T waves. In addition, this arrhythmia is normally a translational point to other dangerous arrhythmias such as ventricular tachycardia or ventricular fibrillation. Ventricular flutter can be severe as well because it can result in sudden cardiac death in an individual.

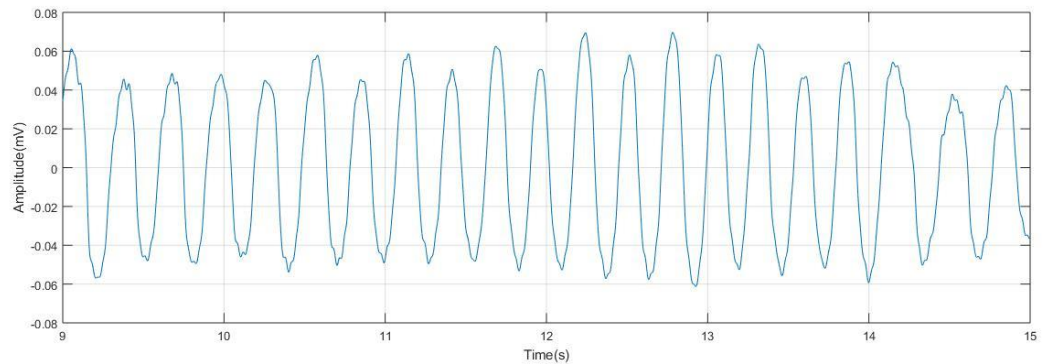

Figure 3.2.6.1.2: Example of Ventricular Flutter Electrocardiogram Display

3.2.6.1.4 Ventricular Fibrillation

Ventricular fibrillation is another arrhythmia caused by an uncoordinated contraction of the cardiac muscles in the ventricles of the heart. This results in the heart's ventricles quivering instead of contracting like they normally would. Ventricular fibrillation is one of the most severe arrhythmias and is commonly found in cardiac arrest patients. The difficulty with diagnosing ventricular fibrillation in a timely manner is that it is hard to detect without the use of an electrocardiogram. Once detected it requires advanced life support techniques to be applied

immediately. Otherwise it is likely to degenerate into an asystole signal, a "flatline" on the electrocardiogram. The asystole leads to a cardiogenic shock and cessation of blood circulation in the individual, resulting in a sudden cardiac death occurring within minutes. If the patient is not revived via a defibrillation device within a timely manner (around 5 minutes at room temperature) irreversible brain damage can occur and they could become brain-dead. However, it is not uncommon for death to occur if the sinus rhythm is not restored to normal within 90 seconds of experiencing ventricular fibrillation, more so if the ventricular fibrillation has already degenerated into a flat line asystole.

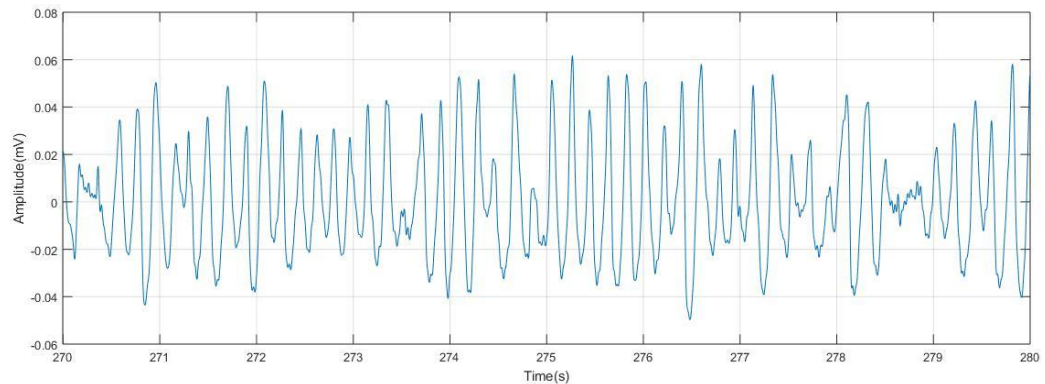

Figure 3.6.1.3: Example of Ventricular Fibrillation Electrocardiogram Display

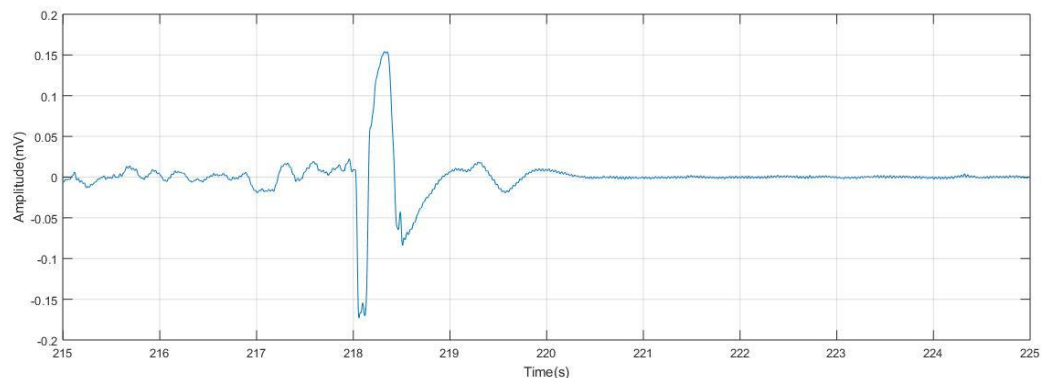

Figure 3.6.1.4: Example of an Asystole on an ECG resulting from Ventricular Fibrillation

3.2.6.1.5 Ventricular Tachycardia:

Ventricular tachycardia is a rapid heartbeat due to improper electrical activity in the heart represented as a rapid heart rhythm. Similar to ventricular flutter and ventricular fibrillation this arrhythmia is potentially life threatening as well. It can cause low blood pressure and can eventually degenerate into a ventricular fibrillation, asystole, or even result in a sudden death.

Ventricular tachycardia is classified using an ECG by determining the duration of the tachycardia episodes that originate from the ventricles. If an electrocardiogram displays three or more beats in a row originating from the ventricle at a rate of greater than or equal to 100 beats per minute then it is often classified as a ventricular tachycardia. Additionally, ventricular tachycardia tends to be put into three categories. Non-sustained ventricular tachycardia, which is if the fast rhythm self terminates within 30 seconds. Sustained ventricular tachycardia occurs if the rhythm lasts for longer than 30 seconds. The third classification is pulseless ventricular tachycardia. During pulseless ventricular tachycardia there is no cardiac output and therefore no pulse. This can lead to cardiac arrest and require treatment similar to if an individual was suffering from ventricular fibrillation.

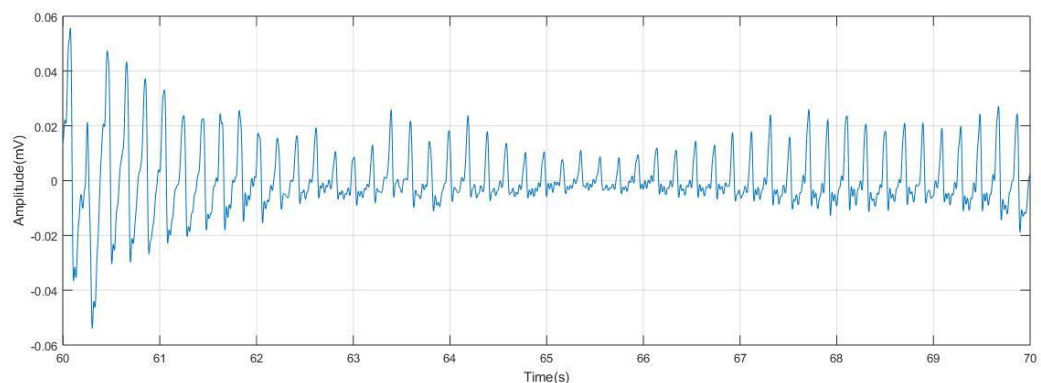

Figure 3.2.6.1.5: Example of Ventricular Tachycardia Electrocardiogram Display

3.2.6.1.6 Cardiac Ischemia

An advantage of using the electrocardiogram is that it can effectively expose metabolic abnormalities in the myocardium. One of the more important abnormalities is ischemia. Ischemia is when parts of the myocardium is not receiving enough blood flow, which is often due to the coronary arteries being diseased. Typically the evaluation of a cardiac ischemia requires the use of a 12-lead electrocardiogram. This is because ischemia change the appearance of the T wave and ST interval and these wave properties require a 12-lead electrocardiogram to be visible. This abnormality in the wave appearances results from a current of injury between ischemic and nonischemic myocardium that alters the main cardiac vector. Although electrocardiogram use is a standard for cardiac ischemia diagnosis the electrocardiogram is not overly sensitive to cardiac ischemia. It is possible that there be ischemia without any grossly prominent changes in the electrocardiogram display. However, larger regions of cardiac ischemia typically result in sizeable changes in the electrocardiogram display. Since these larger regions of ischemia also typically have a higher mortality rate this is a very viable method of diagnosis.

3.3 Sampling and Quantization Theory

The main focus of the wireless wearable electrocardiogram is to acquire and accurately display the wearer's electrical activity of their heart. This signal is typically an analog signal, continuous time and continuous amplitude. In order to be wirelessly transmitted and processed the signal must be converted to a digital signal, which is a discrete time discrete amplitude signal. In order to go from one type of signal to the other the signals must first be sampled and then quantized. There are two methods of sampling. Sampling in the time domain and sampling in the frequency domain. For the purpose of this project we are sampling the analog electrocardiogram signal in time and therefore will mainly discuss the effects of sampling in time.

3.3.1 Sampling in Time

Sampling in time is equivalent to multiplying the analog signal by a periodic train of impulses. This is then followed by a conversion from continuous time impulses to discrete time impulses. Additionally, the Continuous Time Fourier Transform of the continuous time impulse train is an impulse train in frequency. The sampling function in both frequency and time with a sampling period of $T_s = 1/F_s$ are

$$p(t) = \sum_{n=-\infty}^{\infty} \delta(t - nT_s)$$
$$P(F) = F_s \sum_{k=-\infty}^{\infty} \delta(F - kF_s)$$

The sampling of a signal in time can either be the multiplication of the impulse train with the signal in time or the convolution of the signal in frequency with the impulse train. The sampling in time results in forming a periodic signal in frequency, due to the convolution with the periodic impulse train. In the frequency domain this consists of shifted replicas of the Continuous Time Fourier Transform of the sampled signal and is scaled by the sampling frequency.

$$\begin{aligned} X_s(F) &= X(F) * P(F) \\ &= \int_{-\infty}^{\infty} X(\tau) P(F - \tau) d\tau = F_s \int_{-\infty}^{\infty} X(\tau) \sum_{k=-\infty}^{\infty} \delta(F - \tau - kF_s) d\tau \\ &= F_s \sum_{k=-\infty}^{\infty} X(F - kF_s) \end{aligned}$$

The final step in converting the signal from the continuous time domain to the discrete time domain is replacing the time index t with the discrete time index n .

3.3.2 Aliasing

One issue that can arise from sampling is aliasing. Due to the sampling of a signal in time resulting in a periodic representation of the signal in frequency it is possible that the signal in the frequency domain overlaps with other samples of that same frequency. Therefore the sample obtained at a particular frequency could be misleading and actually represent another frequency than that of the originally sampled signal. For example, sampling a continuous time sinusoid,

$$x(t) = a\cos(\omega t + \varphi) = a\cos(2\pi F t + \varphi)$$

results in the discrete time sinusoid,

$$x[n] = x(nT_s) = a\cos(2\pi F n T_s + \varphi)$$

But the issue that arises from sampling is that this sinusoid could be obtained from sampling similar sinusoids such as

$$x(t) = a\cos(2\pi(F + kF_s)t + \varphi), k \geq -F/F_s$$

Or

$$x(t) = a\cos(2\pi(lF - F_s)t - \varphi), l > F/F_s$$

This means that once the signal has been sampled it is hard to determine the frequency of the original continuous time signal because it could be F or $F+F_s$ or $F+2F_s$, etc., or with a phase reversal, F_s-F , or $2F_s-F$, etc. More generally, aliasing can be described as a high frequency signal masquerading as a lower frequency signal. However, an effective method of handling aliasing is to follow the Shannon-Nyquist sampling criteria and make sure that $F_s \geq 2F$, where F is the largest frequency in the signal that is being sampled. This guarantees that the sampled signal can be uniquely recovered after sampling. In addition, high frequency noise aliasing can be handled by placing an analog antialiasing filter, with a bandwidth equal to the bandwidth of the desired signal, before the sampler.

3.3.3 Quantization:

The next step involved in converting an analog signal to a digital signal after sampling is quantization. This is when a quantizer takes in the now discrete time continuous amplitude signal and produces a signal $x_Q[n]$ (where the subscript Q stands for quantized) that can only take on a finite number of values. A common quantization method is called rounding and involves setting the output $x_Q[n]$ equal to kQ , where Q is the quantization step size and k is the integer closest to $x[n]/Q$.

The total number of levels required in quantization tends to be a power of two of the form 2^B , where B is the bits needed for the quantizer. This value can be determined based on knowing the characteristics required for the quantizer. Such as the maximum and minimum value to be encoded (dynamic range), the quantization step size (the difference between each estimation of the signal), and the levels of quantization, represented by L. Where

$$DynamicRange = Vmax - Vmin$$

$$L = \frac{DynamicRange}{Q} + 1$$

$$2^B \geq L$$

$$B \geq \log_2 L$$

This shows that the number of bits required for the quantization step of conversion can be determined based on chosen design variables and vice versa.

3.3.4 Oversampling:

Typically when sampling a signal bandlimited to W Hz it would follow Nyquist's sampling theorem and sample at twice the bandwidth W, $F_s \geq 2W$. To ensure efficient processing and storage F_s should not be much higher than 2W. However the development of oversampling techniques are characterized by very high sampling rates and low resolution quantizers. Typically, the oversampling operation is done in two steps. First, the signal is sampled at a rate KF much higher than the Nyquist frequency. Secondly, after sampling the high rate signal is digitally downsampled or decimated back to F_s . Similar to conventional Analog-to-Digital conversion, this could lead to aliasing of the signal after decimation. In order to avoid aliasing a digital anti-aliasing filter with a cutoff frequency of $F_c < F_s/2$ needs to be implemented before the downsampling operation occurs. Therefore typical oversampling systems contain two antialiasing filters, an analog antialiasing filter preceding the high rate ADC and a digital one preceding the decimation stage. There are two major advantages to sampling signals with this technique. The requirements of the analog antialiasing filter are much less strict than in conventional ADC. Conventionally, a "brick wall" filter (one with very sharp cutoffs) is required to effectively avoid aliasing but since in oversampling systems the Nyquist frequency $KFs/2 \gg W$ a filter with a gentle roll off is acceptable. But now a much stricter digital filter is required prior to decimation to make up for the relaxed roll off of the analog filter. This is easier to realize though since high order digital filters with sharp attenuation tend to be easier to realize than analog filters of similar complexity. Another advantage is that typically oversampled systems offer moderate improvement in signal to noise ratio (SNR) compared to conventional systems. Typically the bandwidth of the quantization noise is $F_s/2$ but in

oversampling systems it is $KF_s/2$. Therefore the SNR in the frequency band of interest will be K times greater than conventional ADC systems although the number of bits in the quantizer remain the same. This makes it so that digital antialiasing filter removes the additional quantization noise that lies above $F_s/2$. However, this is not practical for all applications unless the resolution of the ADC is reduced and the quantization noise is moved to frequencies above the region of interest.

3.3.5 Noise Shaping:

The technique used to move the quantization noise to frequencies above the region of interest is called noise shaping and the most popular technique for noise shaping is sigma-delta modulation. This technique involves analog-to-digital conversion of the integral (sigma) of the difference (delta) between the original signal and the quantized signal. The ADC in sigma delta modulation typically has a very low resolution but high sampling rate. By averaging over many samples the digital antialiasing filter that follows the sigma-delta converter is able to reconstruct the input signal. The sigma-delta modulator can be approximated by the equation

$$y(t) = \int_0^t (x(\tau) - y(\tau))d\tau + q(t)$$

Where $x(t)$ represents the input signal, $y(t)$ the output signal, and $q(t)$ the quantization noise. Additionally in the frequency domain,

$$Y(F) = \frac{X(F)}{1 + j2\pi F} + \frac{j2\pi FQ(F)}{1 + j2\pi F}$$

Based on these equations it is apparent that the output is the sum of a term due to the signal and a term that represents the quantization noise. Furthermore, at low frequencies the signal term approaches $X(F)$ while the quantization noise term approaches 0. In contrast, at high frequencies the signal term approaches zero and the noise term approaches the quantization noise. Therefore, it can be seen that the sigma delta modulator acts as a lowpass filter for the signal and a highpass filter for the quantization noise. This is beneficial because it effectively moves the majority of the quantization noise outside of the frequency band of interest and can then be filtered afterwards to yield a high SNR.

3.4 Wireless Communications

The following sections discuss the various factors that went into choosing the wireless communication device as well as the implementation and settings.

3.4.1 Transmission Standard Comparison

For the implementation of wireless transmissions in our project, the decision between Bluetooth, Wi-Fi and ZigBee chips was a difficult decision when comparing all of the parts. After deciding on the possible chipsets we would use for each standard, we decided to go with Bluetooth for the multiple reasons. Among the many requirements that the project contains, meeting both the size and requirements are at the top of the priority list. Due the limited size of our battery, the need for an effective low energy transmitter was a main priority. Though the 802.11 chipset does contain the fastest data rate, the battery life compared to the Bluetooth and ZigBee modules did not meet with our design constraints. ZigBee although having better battery life than both Bluetooth LE and low power Wi-Fi, does not have the ability to transmit the same amount of data that may be necessary within the project. So after comparing the overall constraints involved with selecting wireless data transmission options, Bluetooth LE was selected since it gave the best overall balance between, size, price, battery life and data rate.

Below is a chart showing a basic comparison of wireless data transmission products.

	Data Rate	Minimum total time to send data (Battery)	Frequencies	Range	Nodes
Wi-Fi 802.11 (CC3200)	6933Mbps	RX: 59 mA TX: 229 mA	5Ghz	500m	8 as router
Bluetooth LE (CC2540)	1Mbps	RX: 17.9 mA TX: 18.2 mA	2.4Ghz	Up to 10m	Up to 8
ZigBee 802.15.1 (CC2630)	250kbps	RX: 5.9 mA TX: 6.1 mA	900Mhz	10-100m	Up to 65000

3.4.2 Bluetooth LE 4.0 Overview

Among the many options for wireless data transmission we considered the various platforms that could be used to transmit the data. After these considerations we decided that Bluetooth would be the best option for us since it provided not only the best battery life options but also the easiest way to transmit data from UART. Bluetooth also allowed us to interface easily with mobile devices. Though there are other Bluetooth modules that provide better transfer rates, ranges and other benefits. For the purpose of this project Bluetooth LE fulfills our requirements the best.

3.4.3 Local Bluetooth LE Network

Bluetooth uses a master/slave network model where the master mode of the Bluetooth sets it's as the master that broadcasts a communications to a single or multiple slave(s) and can send and request data from the slaves and the slave mode for can only send and receive data from the master. For our project the hub that processes and translate the data that will be displayed will have both a master and a slave chip and two other modules on each electrode.

3.4.3.1 Master/Slave Interfacing and Overview

The CC2541 is a dual mode chip which allows it to be set to both the slave and the master programmatically. By having this as an option it provides the project much more flexibility while developing.

3.4.3.2 Data Transfer Rate

The CC2541 supports multiple data rate which range from 250kbps to 2Mbps these transfer rates give us more than enough speed to move the processed data from the device to devices throughout the system. Because the CC2541 is used throughout the project and on each platform there will be no large changes regarding the data rate from platform to platform. The only place where bottlenecking could occur is due to an older Bluetooth standard being used in the Android device.

3.4.3.3 Power Consumption

This module that we selected consumes 14.7ma/14.3ma to 17.9ma/18.2ma of current depending on whether it is a slave or a master respectively for the RX and TX in standby and active mode. However for the purpose of the project the RX and TX will be constantly in active mode as they have to transmit data whenever possible.

3.4.3.3.1 Wrist Mounted Sensor Consumption

For each wrist mounted sensor, the power consumption will be initially set on active receive in order to wait for the transmission which states that the consumption for the device will initially be around 15ma. After it receives the initial signal for the timer synchronization, the processor then switches the data to transmit to output the data to the hub.

3.4.3.3.2 Hub Consumption

Because the hub has both a slave and a master, it will be sending a transmission on its initial start and then set to receive while in the master state in order to meet

all of the initial synchronization settings. Once that message has been sent and is receiving data from the two wrist mounted electrodes the master module will solely be receiving data until the devices are all turned off. So the master Bluetooth LE module

For the slave section of the hub it will be also be in active mode the while the device is on and will only begin transmitting data once it is available in post processing.

3.4.3.3 AndroidConsumption

For the Android connection power consumption there is no set power that can estimated regarding the Android devices battery life due to the varying chipsets being used across multiple devices as well as various forms of Bluetooth implemented across platforms.

3.4.3 Processing

For the data transfer within the system, the current implementation usesAsynchronous connectionless MAC data transfer. This connectionless system allows for fast constant data transmission between both the master and the slave at a rate of about 3ms between transmissions. Because data is constantly streamed between the two connections, possibly losing a few packets will not affect the end results since the errors can be filtered out via software when displaying the data to the user.

3.4.4 Bluetooth Module Settings

This section details the various settings that each Bluetooth module can have and how they were implemented within the project.

3.4.4.1 Synchronization settings

For our model each electrode's slave will have a password and unique identifier for the master module located in the receiver. The Bluetooth modules will be pre-synchronized with the master in order to skip the inquiry step when activating a module for the first time. The main reason for limiting user access for the electrodes is for security and timing situations within the modules.

When connecting to the android device however, it is necessary for the phones master to inquire and input the proper password before data transmission between the hub and the Android operating system.

3.4.4.2 Connection

For the connection within the processor each device will be set to a standard 9600 baud rate since it allows us enough of a transmission rate throughout the device for an easy to read accurate signal.

3.4.4.2.1 Wrist Mounted Sensor

The profile for all Bluetooth settings within the wrist mounted slave sensors is going to be set to active mode. Because the chipsets are all already low energy modules and the devices will be presynchronized with the module from a Bluetooth LE transmission point of view, there is no need to limit the transmission between devices in sniff mode for the wrist sensors.

3.5 Biomedical Signal Processing

Biomedical signal processing is a very broad term. It can refer to genes and protein sequences, to neural and cardiac rhythms, to even tissue and organ images. Its main purpose is to extract important information from the broad spectrum of biomedical signals. This is done via a variety of signal processing techniques, such as analog signal processing, digital signal processing, and/or statistical signal processing. The Wireless Wearable Electrocardiogram aims at using signal processing to provide the user with an accurate representation of their cardiac rhythm and extracting information from this rhythm to help determine the user's heart rate and warn of possible severe arrhythmias.

3.5.1 Biomedical Signal Processing Applications

The human body is constantly communicating information about its health. This is apparent when someone experiences a fever, cold, or even a muscular ache or pain. Typically, this information is gathered via medical instruments that take in a variety of vitals such as a person's blood glucose levels, heart rate, or blood pressure. Additionally, these vitals are traditionally measured at specific points in time and recorded on a patient's chart for future reference. This means that if a patient is to return for additional treatment their diagnosis will most likely be made based on the combination of their current and past visits vital recordings. To make matters worse, physicians typically only see less than one percent of these vitals as they make their rounds to see all their patients. Therefore, medical diagnoses are based off of prior experience and a much smaller data set than one would prefer. Biomedical signal processing allows for the analysis and measurement of typical biomedical vital signals and determine useful information from them. The more information a physician has to base their diagnoses off of the better. This

does a great job of eliminating the trial and error fashion that most diagnosis and treatments are prescribed.

One application of biomedical signal processing is that it provides the ability to have real-time monitoring of patients vitals for physicians. This could lead to better and more accurate diagnoses for patients, or earlier detection of adverse conditions such as heart attacks. The ability for real time monitoring is especially useful in critical care settings where any change in a patient's vitals could mean life or death. Additionally, biomedical signal processing is key to furthering the understanding of the human body. The human body is a multi-input multi-output system working together in a closed loop fashion to preserve life. Everything affects something else. By performing complex analyses on the way the body reacts to different stimuli we could improve our fundamental understanding of the body. This could lead to developing techniques for detecting early indicators of degenerative diseases or just how neurons in the brain interact with one another.

Biomedical signal processing really encompasses all of health and wellness and its impact will only increase as wearables or other biomedical sensors become more mainstream. The Wireless Wearable Electrocardiogram will continue this trend by providing a wearable device for real-time monitoring of the user's heart activity as well as provide early detection of arrhythmias.

3.6 Electrodes

There are multiple types of electrodes that are used to obtain biopotential signals from the human body. Some examples are wet electrodes, dry electrodes, and capacitive electrodes. Additionally, electrodes can vary depending on if they are used invasively or noninvasively. For electrocardiograms the most common electrodes are wet non-invasive silver silver-chloride electrodes. In addition to the silver metal and silver salt of the metal that the electrode is composed of, there often is some form of electrode paste/jelly that is applied between the electrode and skin contact. The combination of the paste and silver metal forms a solution of the metal in the paste at the electrode-skin contact that produces Ag^+ ions. These ions are key for detecting the electric field in the body. When the electric field set up by the dissolving Ag^+ ions is balanced by the forces of the concentration gradient ionic equilibrium will take place. This causes a monomolecular layer of Ag^+ ions to develop at the surface of the electrode along with Cl^- ions. This combination is referred to as the electrode double layer and is where the half-cell potential occurs. This half-cell potential is around .8V in the silver silver-chloride electrodes. The typical equivalent circuit for an electrode consists of resistive and capacitive components. The capacitor represents the double layer of charges separated by the dielectric and the resistance is represented by the non-polarizable behavior of the silver silver-chloride electrodes. However, to accurately account for the fact that impedance does not increase to infinity as the frequency

goes towards zero, a parallel resistance needs to be added. This resistor represents the electrode-electrolyte interface. The electrode-electrolyte interface plays a key role in movement artifact noise. If an electrode is moved with respect to the electrolyte, it can change the distribution of charge at the contact and causes a change in the half-cell potential until equilibrium is re-established. Now if a pair of electrodes are in contact with an electrolyte and one moves while the other does not, it can lead to a potential difference between the two electrodes. And this potential, the movement artifact noise, is a serious cause of interference ECG measurement and instrumentation.

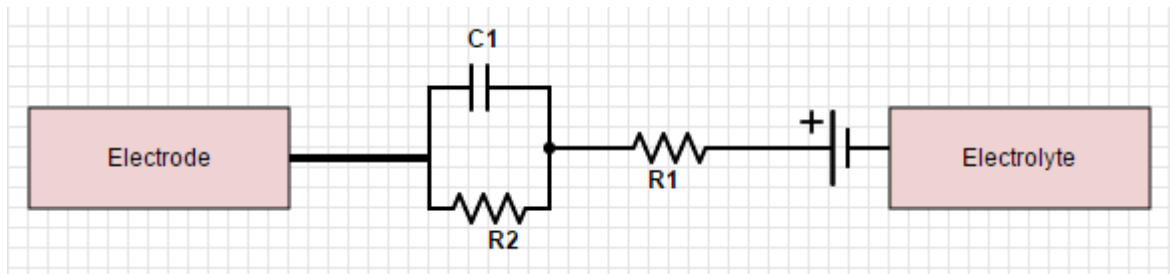

Figure 3.6- Silver Silver-Chloride Electrode (Ag-AgCl) Equivalent Circuit

3.7 Signal Conditioning

The electrocardiogram signal is a very low frequency and low amplitude signal. Typically low frequency and high frequency noise is a much higher amplitude than the desired biopotential signal. In order to accurately display and process a sinus rhythm the signal must be carefully conditioned prior to digitization, transmission, and instrumentation. Conditioning the signal consists of multiple stages of filtering, buffering, and amplification.

3.7.1 Noise Sources:

The main sources of noise that interfere with acquiring accurate electrocardiogram readings are very low frequency motion artifact noise, main/power line noise(60Hz), and common mode noise. If any of these signals are not properly filtered out or conditioned the acquired signal from the electrode will be inaccurate and be overtaken by the noise. Motion artifact noises are the signals in the range 0-5 Hz and tend to come from movement, loose contact of the electrode to the patient, or due to respiration, which causes a baseline drift of the signal. Additionally, power line noise has the same effect on the electrocardiogram signal but at 60Hz. Furthermore, since the typical bandwidth of interest for a diagnostic ECG is from 0.5-100 Hz any frequency above that can be considered noise that

would negatively impact the desired signal. Lastly, a large source of interference is the common mode noise that manifests itself across both terminals of the differential amplifier that is the result of impedance mismatch of the electrode contacts. Due to the mismatch some of the common mode voltage could be mistakenly be converted into differential voltage and displayed in the final output signal.

3.7.1 Filtering/Noise Reduction:

There are multiple methods of noise reduction for these sources of noise that aid in conditioning the desired signal. First of all, a highpass filter with a cutoff frequency of .5Hz will eliminate the motion artifact noise and an analog lowpass filter with a cutoff frequency of 100 Hz will serve as an antialiasing filter as well as eliminate high frequency noise. Additionally, the high pass filter can be implemented either via analog circuitry before sampling or digitally in post processing after conversion. The use of analog filters allows for the directly acquired signal to be much cleaner than the signal would be without high pass filtering. However, by implementing the filtering digitally it allows for a reduction in scale of the analog front end of the device. A notch filter of 60Hz will adequately handle the power line noise and similarly can be implemented via analog or digital filtering techniques. The most effective method of reducing common mode noise is by using an instrumentation amplifier with a very high common mode rejection ratio (CMRR) on the order of 100dB. Another commonly implemented method of common mode noise reduction is the implementation of the driven right leg circuit. Which drives the patient's body with an inverted common mode signal and significantly reduces the common mode noise as well as reduces the strength of the power line noise present in the system. However, this circuit requires the use of an additional electrode in addition to the already attached electrodes. One last method of reducing common mode noise from impedance mismatching is to make sure to use the same electrodes and wires and ensure the age of the electrodes and wires match as well.

3.7.2 Amplification:

After the filtering of the noise sources the resultant signal will be a very low amplitude bio potential signal from the electrode. In order to convert the signal from analog to digital and then accurately processed it must be amplified. This is done via a series of gain stages in the circuit design to amplify the signal enough to be digitized and displayed properly. Alternatively, this step can be done after the instrumentation amplifier stage of conditioning.

3.8 Power Management

A sufficient power source will be needed to power the ECG. Each wristband will have its own individual rechargeable battery with charging circuitry. The hub will be powered by an AC/DC adaptor that will plug into a standard US outlet providing 120 volts at 60 Hz and step down and rectify the voltage to 5 volts DC with a max current output of at least 500 mA.

3.8.1 Rechargeable Battery Technologies

In choosing the right rechargeable battery a comparison between the two leading types of rechargeable batteries needed to be researched. Studies show that between lithium ion and nickel cadmium batteries, lithium ion batteries have a larger energy density than nickel cadmium batteries. Lithium ion batteries also do not suffer the “memory effect” where nickel cadmium batteries are affected by repeatedly charging after a partial discharge and may lose their maximum capacity. The comparison showed that the most suitable battery technology for powering the wristbands was the lithium ion battery for its superiority in energy density, size and weight, and lack of memory effect.

3.8.2 Charging Circuitry

For the prototyping phase the ECG will use 3.7 volt lithium ion batteries connected to an Adafruit USB charging circuit. The charging circuit will be used exclusively for the prototyping stage and the final product will utilize the same charging chip (MCP73833) as the Adafruit circuit on the final PCB. 150 mAh li-ion batteries will be small enough to support the power needs of the circuit while still minimizing size of the total product.

Through early prototyping the combination of two sensors to acquire an ECG signal used only 33 mA at an input bias of ± 5 volts for all dual power op amps combined. Most if not all of the other ICs involved in the WVECG are rated as low power devices and are not expected to draw more than 100 mA leaving the total current draw under the 150 mAh capacity of the chosen lithium ion batteries. This will allow for the wristbands to function up to around 1 hour which is longer than the intended run time of one use (~20 minutes).

If found that the 150 mAh batteries do not match the power needs in terms of capacity, a larger capacity battery will be used. The 3.7v 150 mAh lithium ion battery chosen for prototyping also comes in a 3.7v 500 mAh package albeit slightly larger. In this scenario space used will be compromised for a longer lasting charge to power the device.

3.8.3 DC-DC Converters

DC to DC converters are widely used in portable electronics, the reason being that many portable electronics encompass circuits that require a different voltage level to operate than the battery of the device is outputting. The main electronic methods for converting DC voltages consist of linear regulation, switched mode conversion, magnetic conversion, and capacitive charge pump conversion.

3.8.3.1 Linear Regulators

Linear regulators take an input voltage and output a voltage at a lower level. This is done through power dissipation as the difference in power of the input and output is released as heat. When working with large input voltages relative to output voltages linear regulators are not recommended for their inefficiency in power dissipation. Because of this power loss through heat many linear regulators come with heatsinks attached to their ICs. The large advantage linear regulators have over switched mode regulators is their lack of switching noise.

Low dropout regulators (LDO) have become useful in handheld electronics for their ability to regulate the output voltage when the input voltage is very close in value to the output voltage thus reducing the waste of power coming from regulators in high voltage circuits.

One of the integrated circuits used in the WWECG requires a bias voltage between 2.5V and 3.6V. Since the lithium ion battery selected to power the device provides 3.7V an LDO will be used to drop the voltage down to 3.3V to be usable by the IC.

3.8.3.2 Switched Mode Regulators

Switched mode converters use energy storage components like inductors and capacitors in conjunction with semiconductor devices as switches to temporarily store energy in electric or magnetic fields. Generally field effect transistors (FETs) are used for their switching efficiency to open and close the circuit allowing for the energy to be stored and then released when needed thus increasing (Boost converters) or decreasing (Buck converters) the output voltage from the input voltage.

The benefits of using switch mode regulators include their efficiency in terms of power loss. Where linear regulators are considered inefficient in high voltage scenarios due to the power dissipation through heat, switched mode regulators are considered to be more efficient in that there is no loss through heat.

Switching regulators which utilize components such as inductors to store energy in a magnetic field make up the magnetic conversion portion of DC-DC converters. The main drawback of switched mode converters that use inductors is the

electromagnetic interference caused by the generating and collapsing of magnetic fields in the inductors and also transient responses at high switching frequencies.

Many of the ICs used in the WWECG require a bias voltage of 5V. As the battery selected provides 3.7V a boost converter will be used to bump up the voltage from 3.7V to 5V.

3.8.3.2 Capacitive Charge Pumps

Capacitive charge pumps are switching regulators that use capacitors to change the input voltage into a higher or lower output voltage. Capacitive charge pumps lack inductors and therefore do not produce any electromagnetic interference. Charge pumps can also be used to invert the input voltage.

The dual supply op amps used in the sensor require a bipolar supply to bias them. For this reason a charge pump will be used to invert the stepped up 5V from the boost converter to -5V and will supply the op amp a negative voltage to bias the –Vcc pin.

3.9 Data Converters

Typically data is transmitted and viewed as either an analog signal (continuous time, continuous amplitude) or a digital signal (discrete time, discrete amplitude). Due to the design of the wireless wearable electrocardiogram it will be necessary to move from both types of signals often. A conversion of analog to digital will be needed for Bluetooth wireless transmission of the acquired biopotential signals and to be processed by the digital signal processor. In contrast, the signal that is received after transmission will need to be converted from a digital signal to an analog signal to serve as inputs into the instrumentation amplifier and output the desired ECG signal. Therefore both analog to digital converters (ADC) and digital to analog converters (DAC) will be used.

3.9.1 A/D Converters

Ideally, an analog-to-digital converter takes in an analog input signal that lies within a certain range and is able to uniquely represent its continuous amplitude with a limited number of digital outputs. The theoretical ideal transfer function of an ADC would simply be a straight line but practically it represents more of a staircase where the center of each step is in line with the ideal straight line. The ADC consists mainly of two steps, sampling and quantization. Both of which are explained more in depth in section 3.3. Sampling consists of measuring the signals continuous amplitude at discrete intervals in time. And quantization involves estimating the continuous amplitude and evaluating it within a discrete range of values. Naturally this estimation introduces a small amount of error often referred

to as quantization error. As the number of discrete codes that represent the sampled signal's amplitude decreases the width of the steps of the practical ADC transfer function. Approaching the ideal straight line of the ideal ADC transfer function. The step width of the ADC is normally referred to as the least significant bit and is used as the reference unit for other quantities in the specification. Additionally, since it defines the number of divisions of the full analog range it is referred to as the resolution of the converter. The resolution of the converter is normally expressed in terms of the number of bits that the output code will result in.

3.9.1.1 Types of ADCs

Throughout this project there were multiple types of analog-to-digital converters, throughout this section lists which were implemented and why they were chosen for the WVECG.

3.9.1.1.1 Flash ADC

A flash analog-to-digital converter has a bank of comparators that samples the input in parallel and individually outputs for their decoded voltage range. This bank then feeds into a logic circuit that generates a code for each voltage range. This converter tends to be very fast, capable of gigahertz sampling rates, but usually has a small resolution.

3.9.1.1.2 Successive-Approximation ADC

The successive approximation ADC uses a comparator to successively narrow the range the input voltage could fall between. The converter compares the input voltage to the output voltage of an internal DAC that might represent the midpoint of the selected voltage range, at each successive step. After each step in the approximated output is stored in a successive approximation register until the desired resolution is reached. This method is very similar to a binary search algorithm.

3.9.1.1.3 Sigma-Delta ADC

The sigma-delta ADC over samples the input signal by a large factor and filters the signal band. Then a smaller number of bits than required are converted using a Flash ADC after the filter. An error from the discrete levels of the Flash ADC is created as well. Then the converted signal and error signal are fed back and subtracted from the input to the filter. This creates a negative feedback that has the effect of noise shaping the error so that it does not appear in the desired

signal's bandwidth. Lastly, a digital filter follows the ADC to reduce the sampling rate, filter unwanted noise, and increases the resolution of the output.

3.9.2 D/A Converters

Similar to an ADC the theoretical ideal transfer function of the digital-to-analog converter would also be a straight line. However, in practice it is more of a series of points that fall on the ideal straight line. This is because the DAC represents the limited number of discrete digital input codes by a similar number of discrete analog output values. The LSB of a DAC represents the height of a step between successive analog outputs from the converter. And the resolution of the DAC is the number of possible output levels the DAC is designed to reproduce. A way to view the DAC is as a digitally controlled potentiometer whose output is a portion of the full analog voltage determined by a corresponding digital code. Typically the DAC will convert the digital codes that represent a certain analog value into a series of impulses that will then need to be processed by a reconstruction filter. The DAC results in a piecewise constant or staircase-shaped output which is equivalent to a zero order hold operation and effectively multiplies the frequency response of the reconstructed signal by a sinc function. This results in low level noise added to the reconstructed signal at multiple harmonics above the Nyquist frequency. However, similar to using an anti-aliasing filter with a cutoff frequency of 1/2 of the Nyquist frequency before ADC, the errant noise can be filtered out by using a low pass filter acting as a reconstruction filter with cutoff frequency 1/2 the Nyquist frequency. This is effective for constructing a smooth analog signal from a digital input. Another effective method of removing the noise is to oversample the signal and noise shape so that the undesired noise lies much above the desired bandwidth of the reconstructed signal and can easily be filtered out.

3.9.2.1 Types of DACs:

Throughout this project there were multiple types of digital-to-analog converters, this section lists which were implemented and why they were chosen for the WVECG.

3.9.2.1.1 Pulse-Width Modulator

The pulse-width modulator DAC involves using a stable current or voltage that is switched into a low-pass analog filter with the duration that is determined by a digital input code.

3.9.2.1.2 Delta-Sigma DAC

The delta-sigma DAC employs the oversampling technique and allows for the DAC to use a lower resolution internally. This DAC is driven with a pulse-density

modulated signal, which is created with the use of a low pass filter, step nonlinearity, and a negative feedback loop. This will result in a high pass filter acting on the quantization noise and steering it into the high frequencies that are of little interest. This noise can then be filtered out later via an analog low pass filter.

4 Standards and Constraints

The following section gives an overview of the standards and constraints that occur within the project.

4.1 Government Regulations

Because the WVECG can be classified as a medical device, it was necessary to review and comply with all government regulations.

4.1.1 HIPAA Medical Data Security and Privacy

When considering the application of HIPAA to our project it solely applies to “converted entities and business associates” according to the US Department of Health and Human services. Because this project is a proof of concept and will not be used for any business purposes as well as it not being a covered entity since there are no current sponsorships the standard HIPAA requirements for the privacy and security of user data collected by the devices does not apply to this current project. This project does also not need to use user data since none of the data within our testing will come from actually people as that would violate clinical trial regulations. Further information on this topic and the definition of “Covered Entities and Business Associates” can be found within “160.102 Applicability”.

4.1.2 Radio Frequency Devices FCC

Because the device uses Bluetooth LE ISM frequency of 2.4 GHz that meets all regulations set regarding the Federal Communications Commission’s Electronic Code of Federal Regulations “18.301 Operating Frequencies”.

4.2 Bluetooth LE Hardware Constraints

Though Bluetooth LE has many great benefits and uses there are still limitations to the technology as described below. Although Bluetooth LE has these constraints when compared to other technologies it provides the best specifications for this given project.

4.2.1 Range

For the Bluetooth module selected, the HM-11, the current accurate limitation is 50ft due to the antenna the AN058 from Texas Instruments. This transmission will also be restricted to an open air environment since Bluetooth transmits with a 2.4 Gigahertz frequency which does not allow accurate transmission through walls.

4.2.2 Transmitters needed for each Device

Due to the master-slave format that Bluetooth LE has and the way Android handles Bluetooth the devices used throughout our project, there is a need for at least one Bluetooth module on each device for transmission purposes. However the problem occurs, due to Android being unable to be set to a slave. Because the android device cannot be set as slave for receiving the data, the central hub device needs to have a separate Bluetooth LE module for both the wrist mounted sensors as well as the Android device. With the master module being used for the sensors due to timing constraints and the slave used for the android device this technology adds one more sensor.

4.2.3 Latency

Though the latency limitation for the 6ms for Bluetooth LE and the CC2541, the due to the application we are using we will be using 10 second latency transmission to the central hub. The reason the latency is increased is due to the benefits in accuracy received throughout the transmission. However when connecting to the Android device, the new latency will be increased to 30ms in order to provide an easier sampling rate for the mobile device.

4.2.4 Data Rate

For the over the air data rate on the on both of the Bluetooth modules, we will be attempting to achieve a data throughput rate of 50kbps since the physical layer rate is 1Mbps. The same data rate applies from the central hub to the Android device.

4.3 Bluetooth Software Security Standards

In order to meet HIPPA compliance requirements each of our Bluetooth modules will be fitted with a password in order to stop the possibility of malicious activity using the data transmitted. Bluetooth LE is also encrypted with a 128bit AES

Counter Mode CBC-MAC mode. There is also the possibility of application layer based encryption being used when transmitting to the Android Application with SSL.

4.4 Testing Constraints

Because the WWECG is a wearable device and features readings that come from the body via an electrode of the largest constraints when testing is testing and simulating a person without actually using a person. Even with consent of the individual as to not violate the Nuremberg code, research on human subjects without proper certification at the university violates policy.

5 Design Plan

The physical design plans for the WWECG consist of two adjustable wristbands (made either of an elastic material that stretches to accommodate for wrist size or a plastic strap with an adjustable clasp) and a central hub used for externally processing data and sending it to the Android app.

Figure 5.1 below shows the inner and outer sides of the wristband. The inner side of the wristband contains only the electrode clip to snap onto electrodes that will sit on the palm side of the user's wrist or forearm. A lead will connect the electrode snap from the inner side to the signal conditioning circuit before being converted to digital data to be transmitted. The outer side of the wristband will also house the charge management portion of the device including a 3.7 volt lithium ion battery, charge controller, boost converter, and a split rail converter for dual supply bipolar op amps used for active analog filtering. A female micro USB port will be located next to the battery that will be used to lock into the hub for charging and clock synchronization. A microprocessor and Bluetooth transmitter will also be located on the outer side of the wristbands. While a significant portion of the electronics could be transferred to the inner side of the wristbands to further reduce their size, we find that having only the electrode snap on the inner side will provide the most comfort for the user.

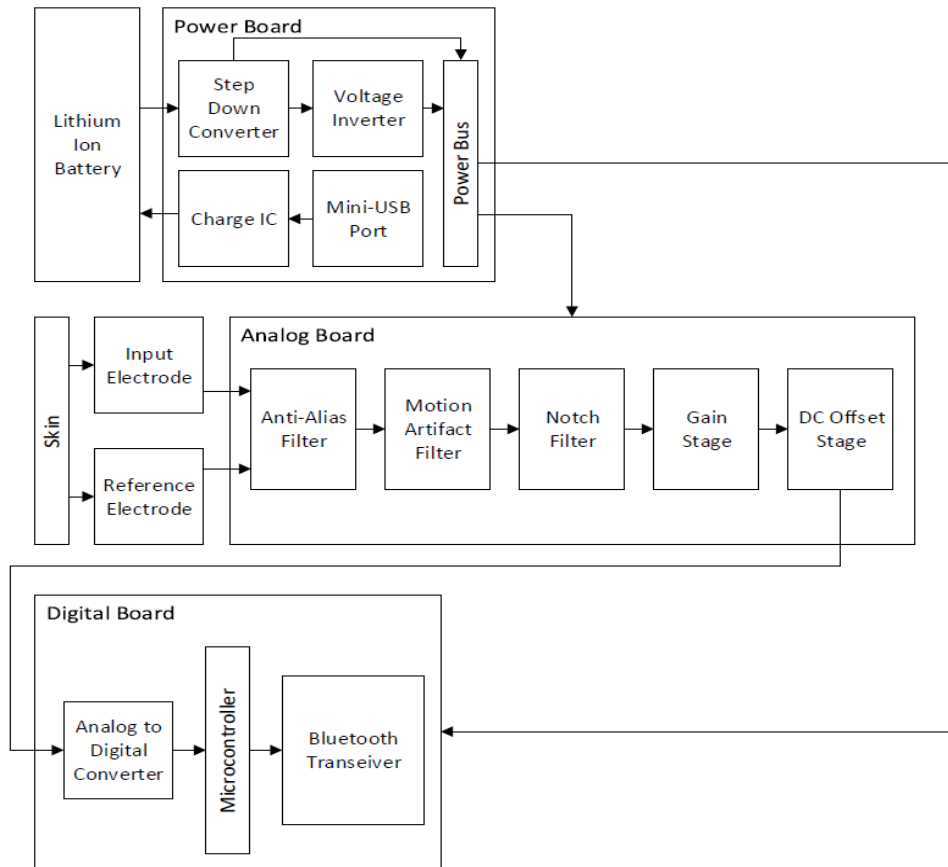

Figure 5.1- Inner and outer sides of the wristbands

Figure 5.2 shows the hub which will externally process the ECG signal and send it to the Android app. The hub will also act as a charging station and clock synchronizer through the two male USB ports located in the middle of the hub. To provide power to the hub a female micro USB port will be integrated into the system to allow the user to connect to a power source using a micro USB to USB 2.0. These cables are very common and are convenient as many outlets now provide USB 2.0 ports for USB charging options.

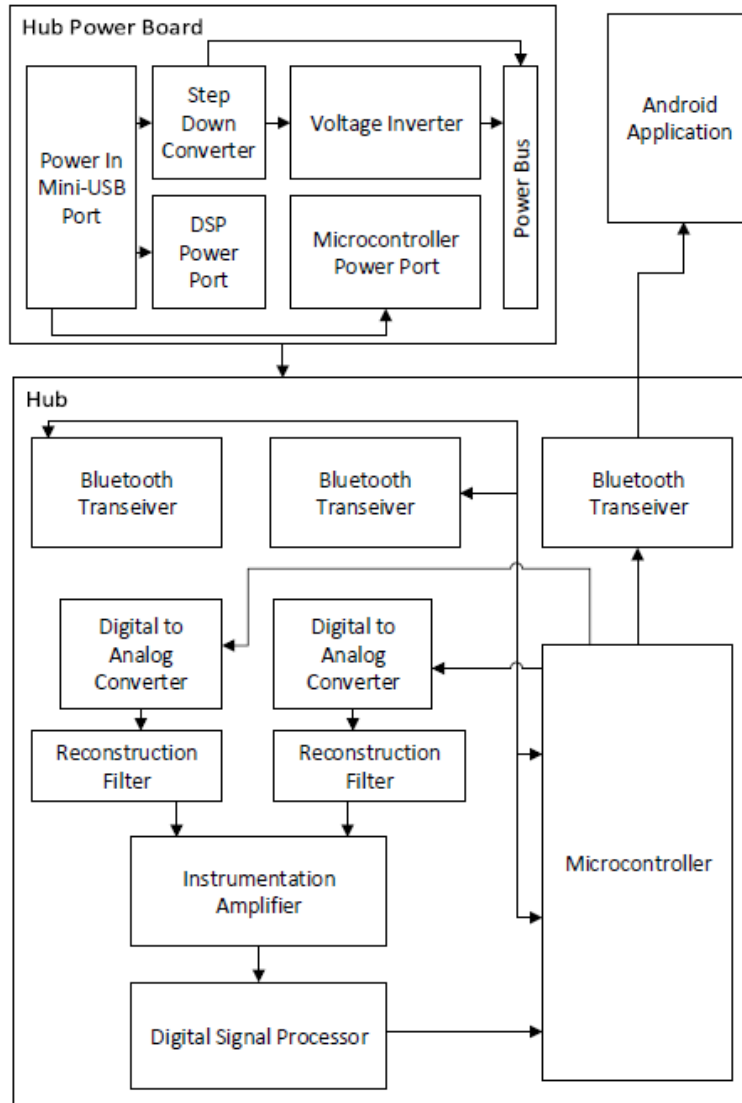

Figure 5.2- External processing and charging hub

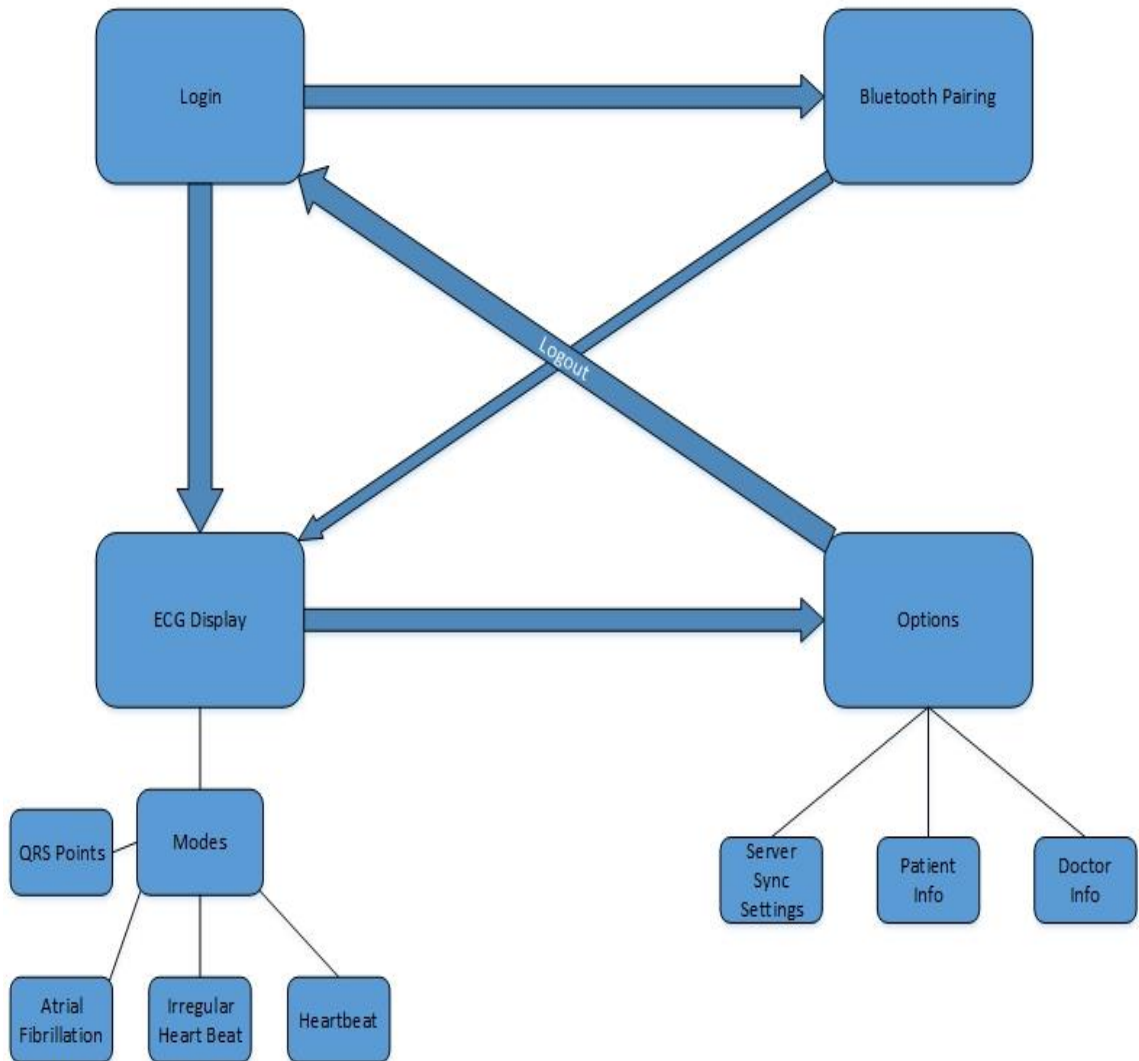

Figure 5.3- Software diagram

5.1 Electrode to Electrode Sampling Synchronization

One of the largest problems that needed to be solved when using designing and implementing the wrist mounted electrodes for sampling is getting the correct timing between signals wirelessly transmitted to the receiver. In order to achieve a proper rhythm strip from the heart, the difference in timing between the electrodes signals needs to be known before any type of processing can be done on the signals and outputted through Bluetooth LE to the android device for display.

5.1.1 Timestamping

In order to achieve a proper sampling synchronization, it was determined that the best way to handle the synchronization was to use a timestamp for each device. Even though the crystal on both chips may be the same, it is impossible to determine whether or not the actual clock rates on each device will be exactly the same. Because of this issue the decision was made that timestamping each transmission was the best way to achieve the most accurate results possible. In order for each signal to have a timestamp, it is necessary that there is a consistent time is kept.

5.2.1.1 Timestamp Design Options

In order to decide what was the best option for timestamping each individual device

5.2.1.1.1 CMOS Timestamping

Add a CMOS battery to each modules within the system in order to maintain the time on each chip with up to 1us of accuracy with a Real Time Clock or RTC running whenever the device is powered off on each device. So each instance of the system on initialization will be able to maintain the same time throughout each device. Only needing to update the current time to the individual microcontrollers that all have the same time for processing would create a consistent manner of measuring the difference between electrodes.

5.2.1.1.2 Software Signal Timestamping

Send out a timestamp hosted by the Hub device to send out an original timestamp with both devices equidistant to the hub and start the timestamp then. This would occur by placing both wrist mounted electrodes on the hubs Bluetooth masters and transmitting a start time from both modules at an simultaneous time when ready with a timestamp. After this timestamp is received by both wrist sensors, they begin collecting and transmitting data to the back to the hub with the new timestamp that was calculated from a timer on each board with a simultaneous clock rate along with the necessary rhythm data. Once the message and timestamp are ready, they are sent to the hub where the actually rhythm strip will be processed with the new timestamps from each device then outputted via the Android application.

5.2.1.1.3 Timestamp Implementation

After heavily considering both options, the decision was made to go with the second decision since it will likely be easier to implement. The first option though likely simpler to operate would create another layer of complexity from the

hardware perspective that would likely cause more harm than good when implementing the necessary items. The second option however will require a heavier embedded software implementation but will also allow for reduced size and weight on each wrist-mounted electrode. The processed is also displayed below Figure 5.1.1.

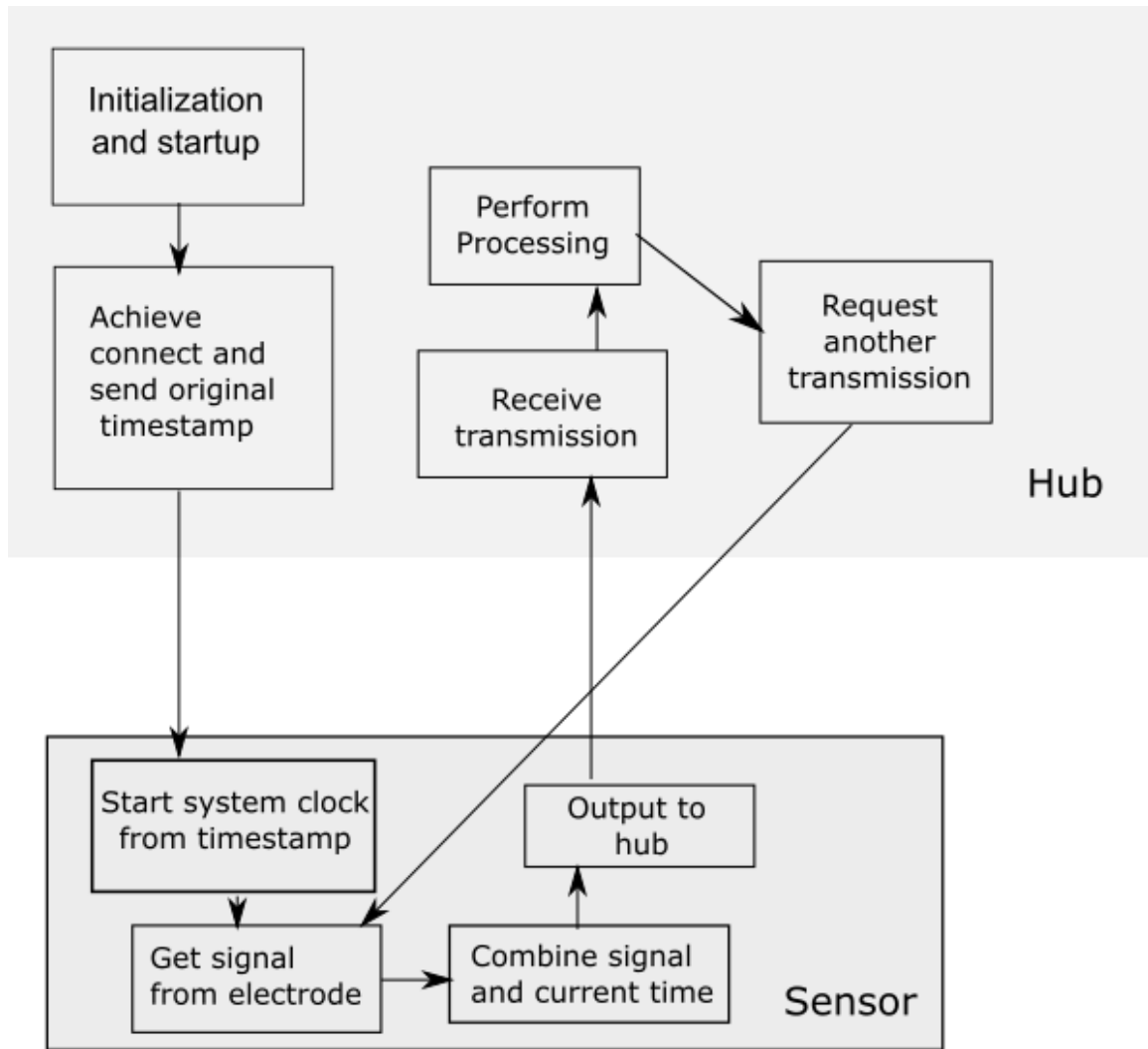

Figure 5.1.1 above figure displays the implementation of the devices timestamping process in order to achieve an accurate synchronization between all individual sensors.

5.3 Firmware and Software Plan

For the overall programming aspects of design and implementation, Object Oriented Design will be used. Though the projects embedded software will be mostly implemented using C, it was determined that Object-Oriented Design

aspects would still be best for the implementation of this project since it will help improve modularity throughout the implementation and debugging steps as well as allow the software to be more organized and fluid. Below are graphs and briefs descriptions of the project's implementations.

5.3.1 Electrode Sensors

This section displays the data flow and the overall class diagrams for the Hubs embedded software.

5.3.1.1 Data Flow

The data flow diagram below shows how data is collected and then moved throughout of the system.

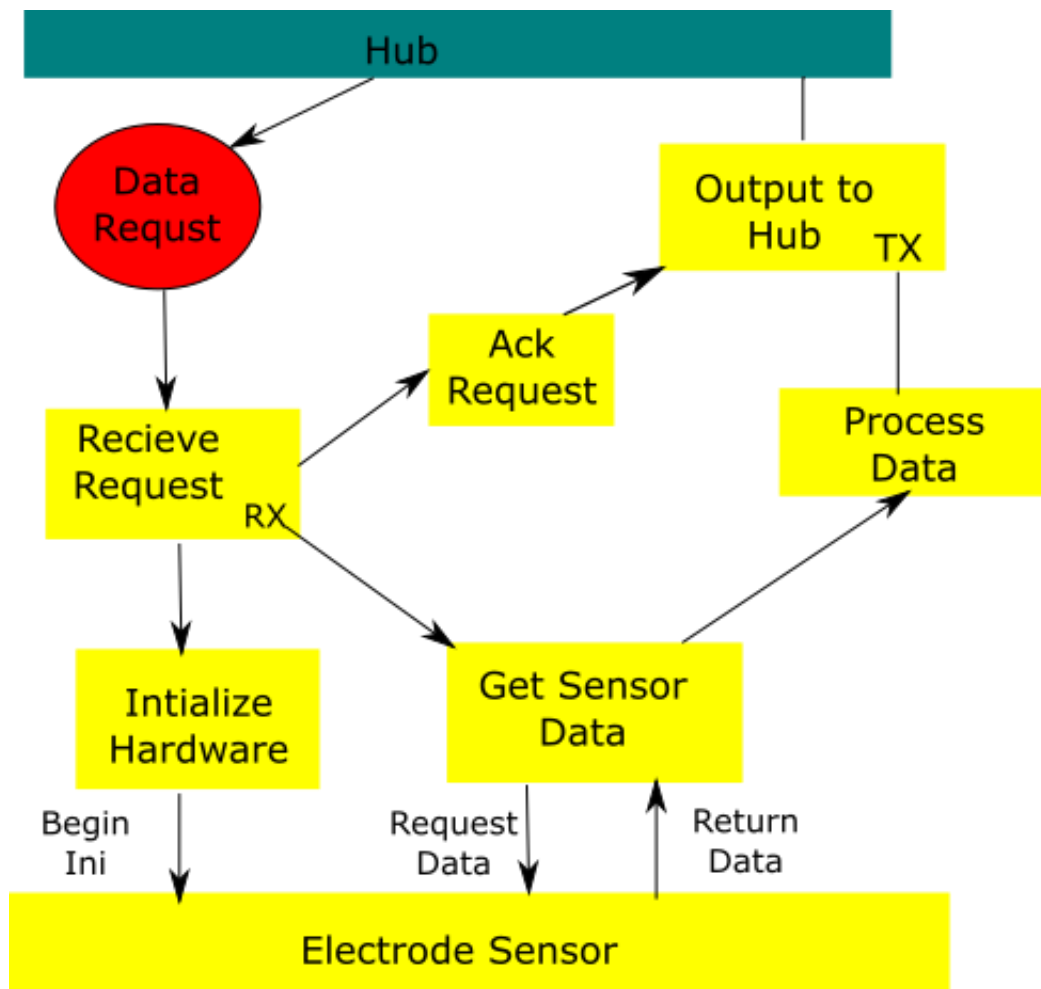

Fig 5.3.1.1 below displays the data flow of an electrode node.

5.3.1.2 UML Class Diagram

Referencing the diagram in **Figure 5.3.1.1** below, one can observe the overall structure that the embedded software design. Featuring a main thread to move data between classes this software implementation allows a modular approach to increase ease of debugging.

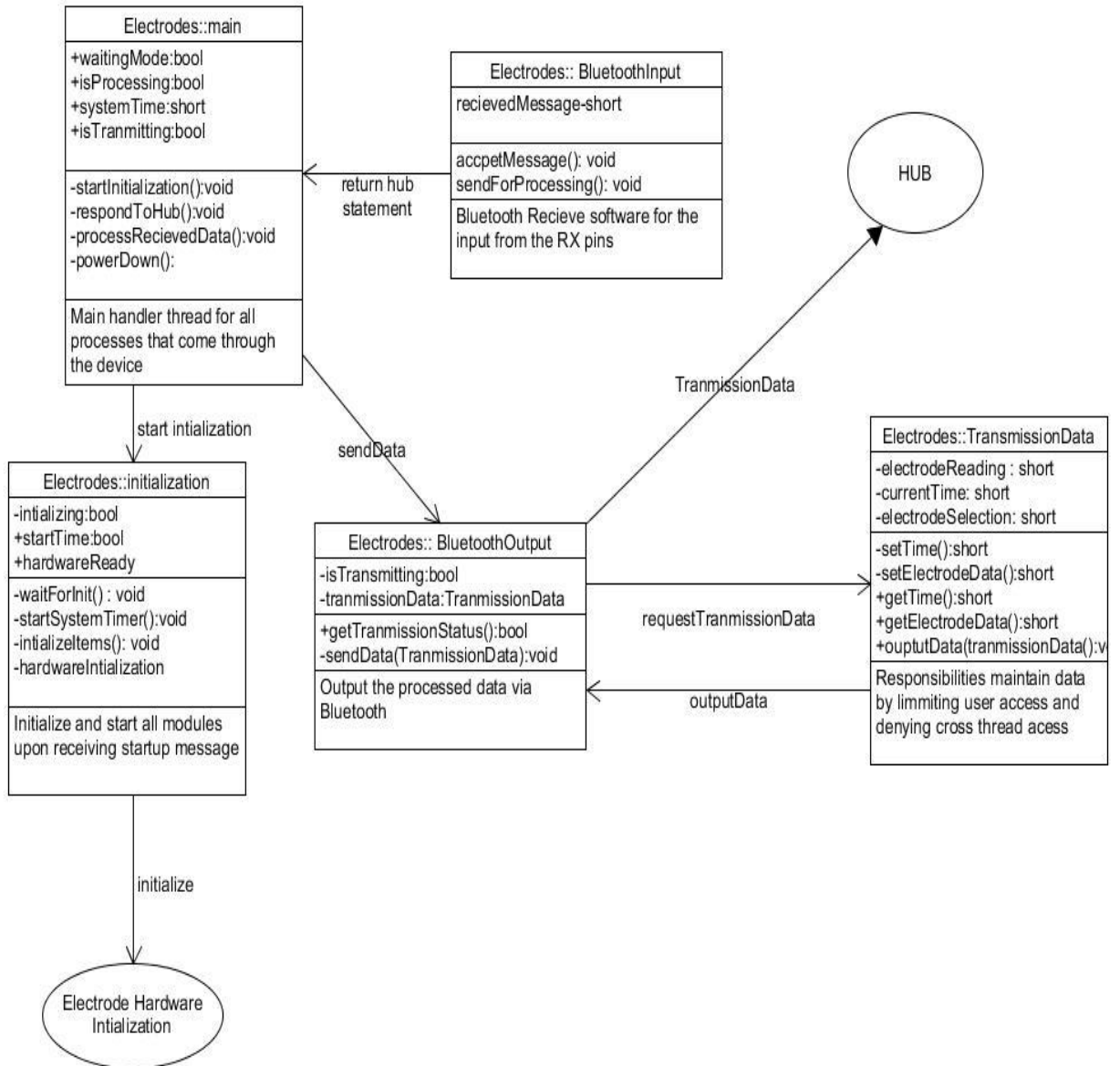

Figure 5.3.1.2-Electrode sensor UML Diagram

5.3.2 Hub

This section displays the data flow and the overall class diagrams for the Hubs embedded software.

5.3.2.1 Data Flow

The data flow **Figure 5.3.2.1** below displays how the electrode sensor data and is moved throughout the system. Starting at the MCU in the hub, the electrode data is requested then transmitted back to the hub for processing. After processing it is outputted to the Android device.

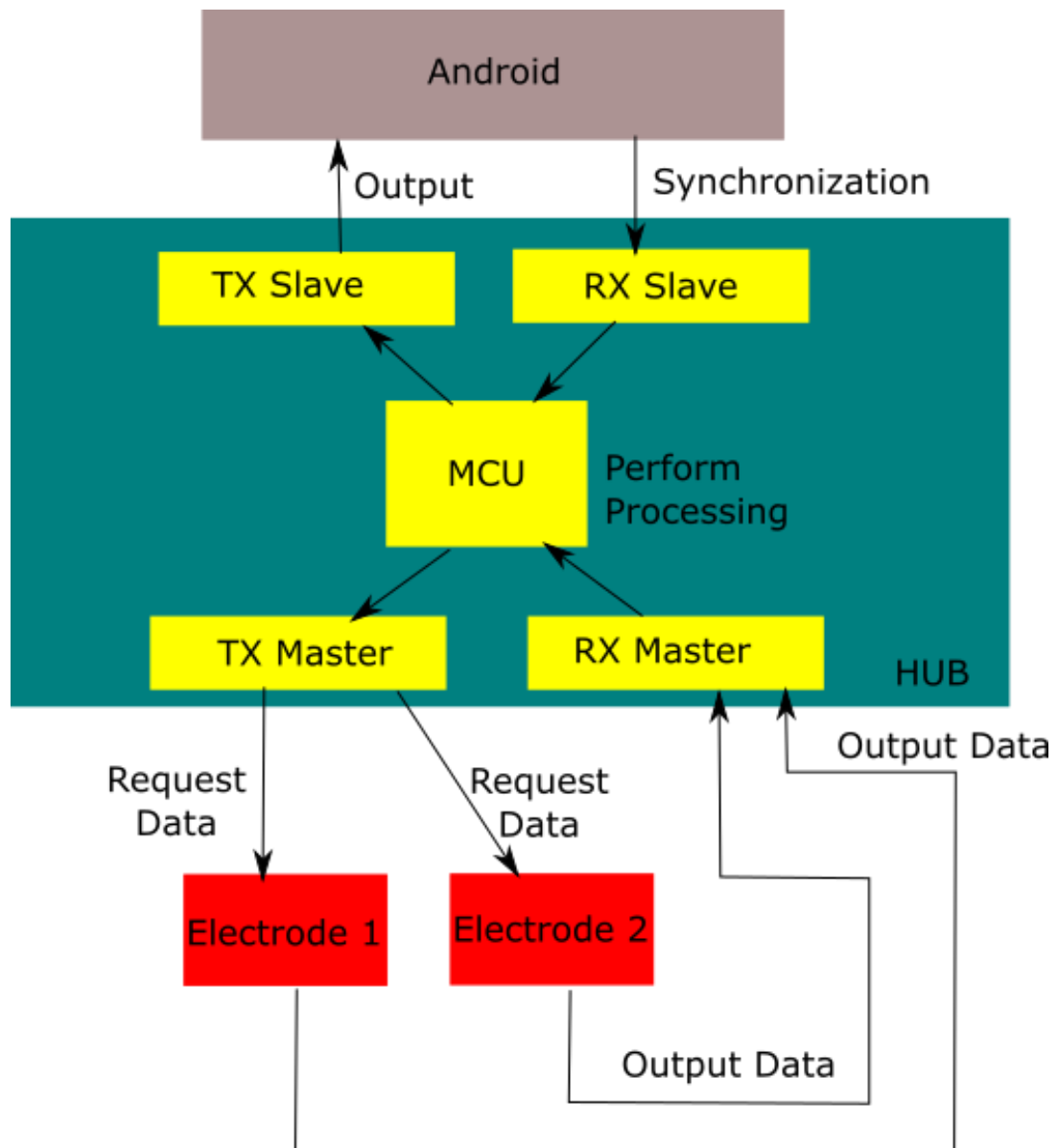

Figure 5.3.2.1-Hub data flow diagram

5.3.2.2 UML Class Diagram

The focusing on handle the end processing and calculating for the rhythm strip. The hub is in charge of the hardware initialization for the system excluding Android. Connected to all devices within the system, the hub is designed for translation between the output of the electrode sensors and the data output viewed and store by the users. The UML diagram can be seen below in **Figure 5.3.2.2**

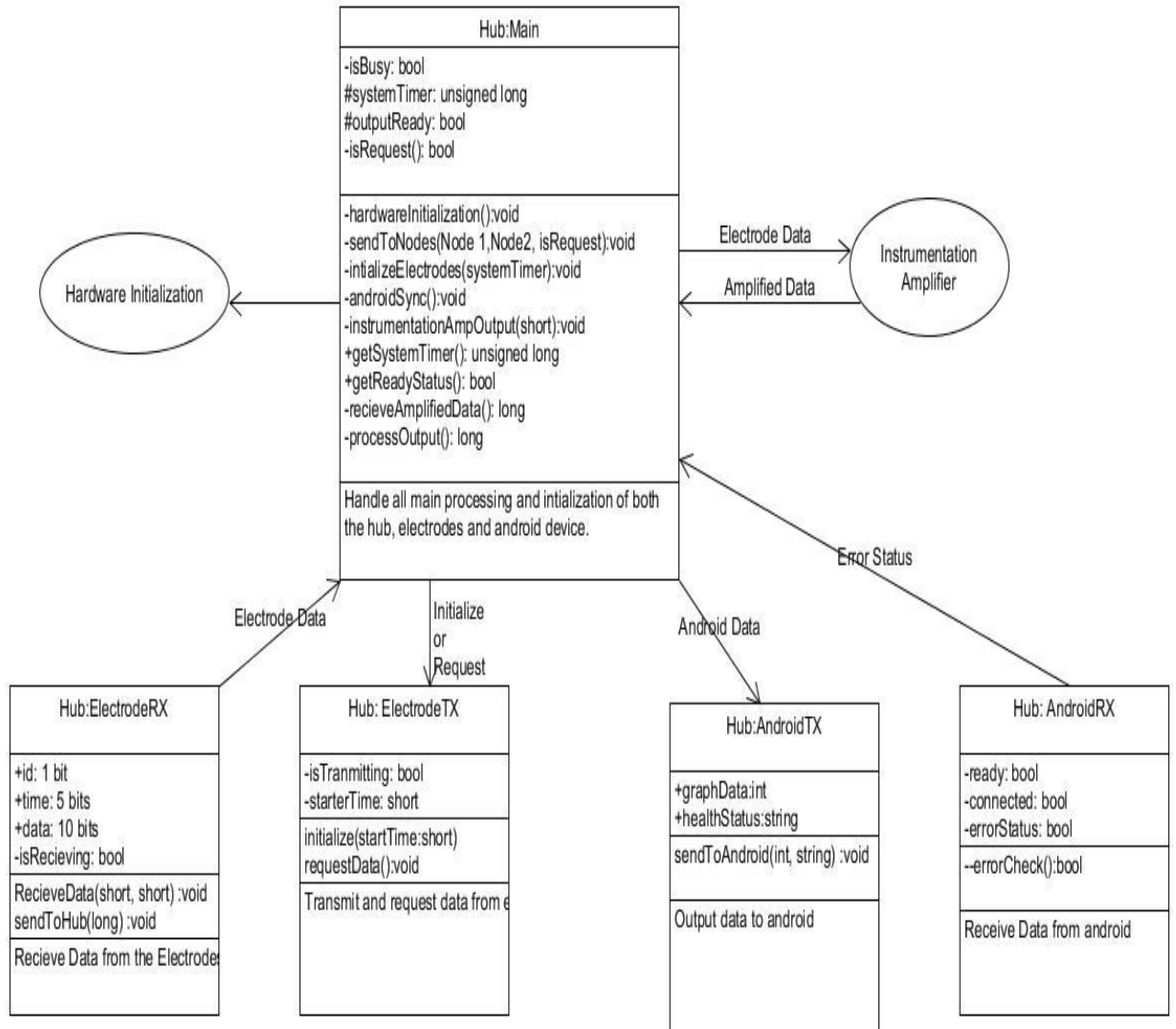

Figure 5.3.2.2-Hub UML diagram

5.3.3 Android Application

This section contains the UML class diagram and the application activity flow for the Android application.

5.3.3.1 Application Flow

For the application flow chart in **Figure 5.4.3.1** below Circles indicate actions, squares indicate a dialog or a screen, arrows indicate flow, dotted lines indicates that you can press back to go to the previous screen.

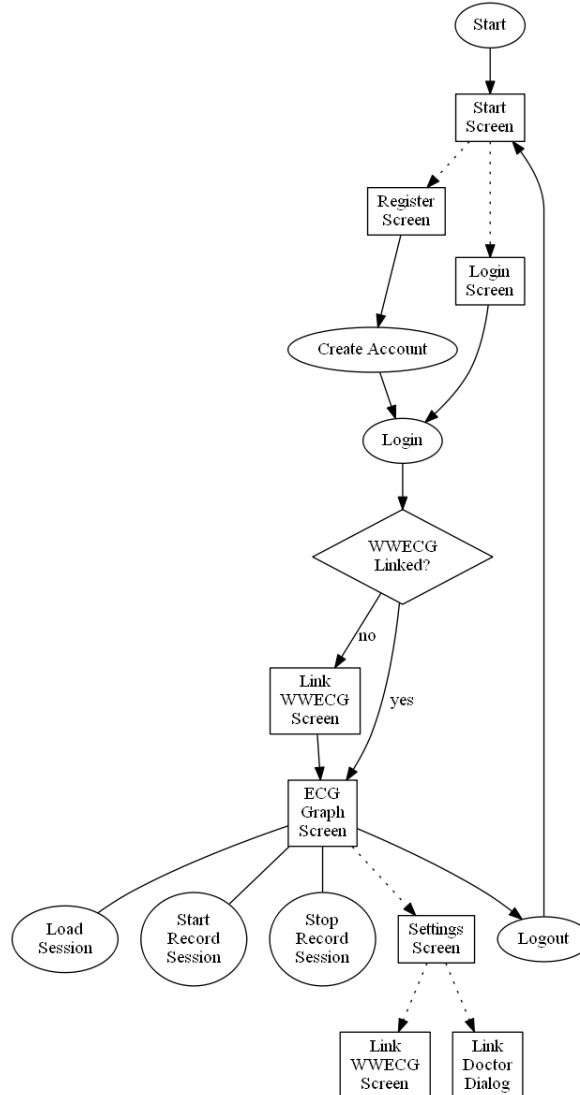

Figure 5.3.3.1 Application Flow Chart

5.3.3.2 UML Class Diagram

The UML class diagram in the following pagelists the overall design for the Android application. See client side specification in **section 7.3** for further details regarding the app

5.4 Hub Receiver and External Processing

This section discusses the processing techniques of the hub and the receiver.

5.4.1 Post-Transmission Preprocessing

This stage of the design consists of recreating the Bluetooth LE transmitted signal via Digital-to-Analog converters. We will be using the Texas Instruments MCP4725 16-bit Digital-to-Analog converters due to their low powered nature and high accuracy. Afterwards, the signal will be passed through reconstruction filters similar to the antialiasing filters on the analog front end of the sensors. The -3db frequency of these reconstruction filters will be 100Hz, the same as the antialiasing filters. After successful reconstruction the signals will go through the instrumentation amplifier to remove the common-mode noise seen at the electrode inputs. To complete this task we are using the Texas Instruments INA333 due to its very high Common-Mode Rejection Ratio and low power. This instrumentation amplifier is commonly used in many ECG applications. At this point we will have the desired representation of the Electrocardiogram signal and it will next go through Analog-to-Digital conversion to be passed to the Digital Signal Processor to implement our designed signal processing algorithms. For the Analog-to-Digital conversion we will be using the ADS1251 due to its noise shaping ability since it is a sigma-delta modulating ADC, which reduces quantization error and provides a cleaner signal to the DSP. We are using the TMS320C5535 DSP to implement the algorithms due to its low power nature and the flexibility that software implemented DSPs provide.

5.4.2 Digital Signal Processing Algorithms for ECG signal

Prior to any algorithm implementation it is first necessary to do some preliminary ECG signal pre-processing and filtering on the digital end. For QRS detection it is necessary to estimate the energy in the QRS frequency band.

Pre-Processing/Filtering Steps:

1. Filter with a FIR Bandpass filter with pass band of 5-26 Hz.
2. Take the derivative of this bandpass filtered signal.
3. Take the absolute value of the resultant signal.
4. Average the absolute value of the signal over an 80 ms window.

5.4.2.1 QRS Complex Detection Algorithm

The QRS complex detection algorithm is based on the popular Pan and Tompkins algorithm. It consists mainly of a peak detection algorithm. First a threshold is determined based on the mean estimate of the average QRS peak and the average noise peak. Additionally, this threshold is automatically adjusted throughout the algorithm's implementation. The peak will then be classified as either noise or a QRS complex based on whether it surpasses the detection threshold or not. There are 4 main rules that the algorithm follows to accurately differentiate between a QRS detection and a noise peak.

Rule	Description
1	Ignore any peak that either precedes or follows a larger peak by less than 196ms.
2	If a peak is detected, then now refer back to the original raw signal and determine if that segment contains both negative and positive slopes. This correlates to a peak being found in the raw signal. Otherwise, the detected peak simply represents a baseline shift.
3	Compare the reported peak to the detection threshold. If larger than the detection threshold the signal is classified as a QRS complex. Otherwise, the signal is classified as noise.
4	Lastly, classify a peak as a QRS complex if no other QRS has been classified within 1.5 R-to-R intervals, but a peak greater than half the detection threshold followed the previous QRS detection by at least 360ms.

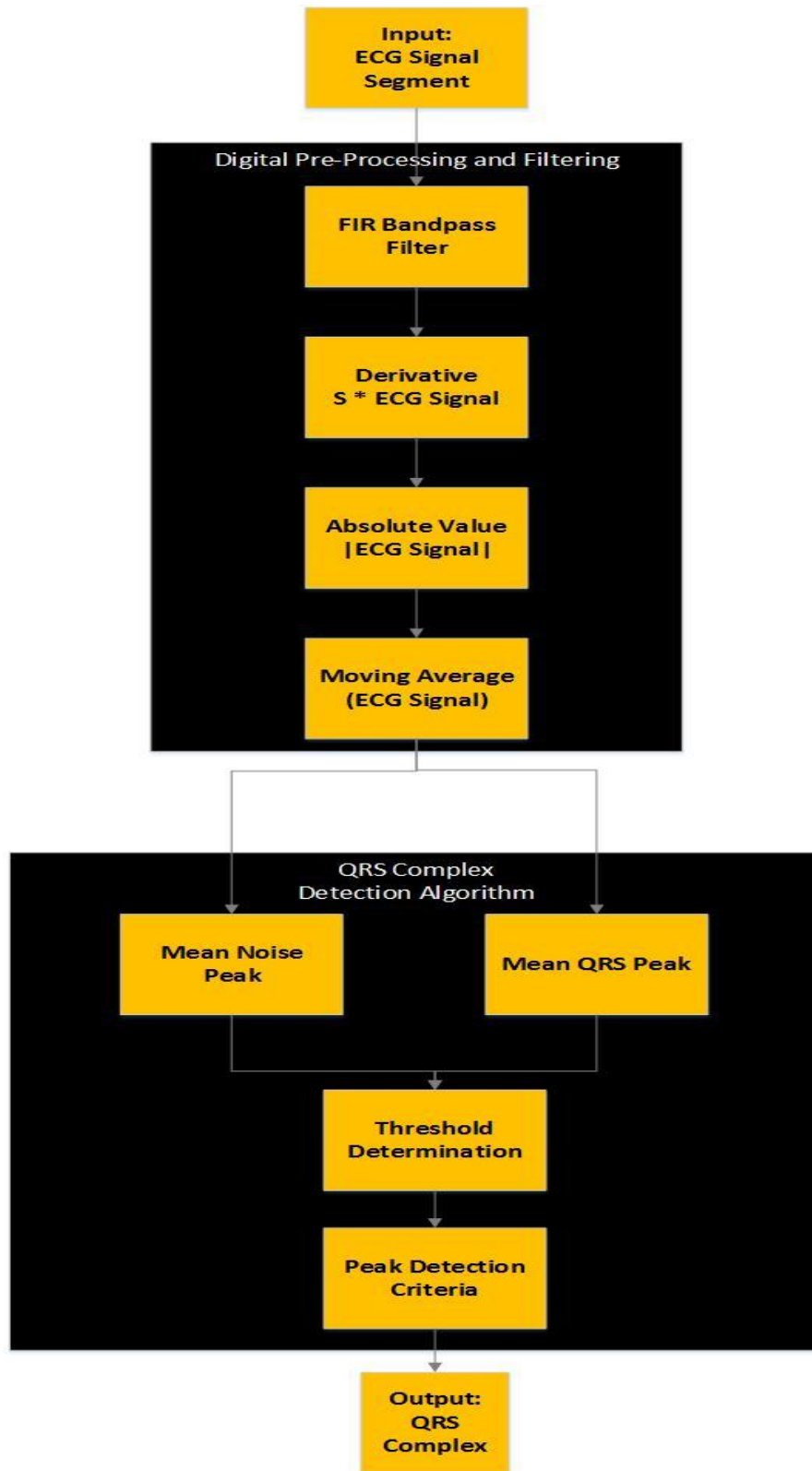

Figure 5.4.2.1 QRS Block Diagram

5.4.2.2 Heart Rate Calculation Algorithm

The algorithm for heart rate calculation is quite simple. It simply counts the number of QRS complexes occurring over a six second interval and then multiplies that count by ten. This method requires working in conjunction with the QRS complex detection algorithm to maintain accuracy.

5.4.2.3 Ventricular Arrhythmia Detection Algorithm

Similar to the QRS complex detection algorithm, the Ventricular Arrhythmia Detection Algorithm is based on a combination of peak detection and power spectral density analysis of the ECG signal. However, prior to algorithm implementation it is important to first extract the specific features we are interested in. This involved first analyzing normal sinus rhythm signals vs. arrhythmias based on data provided by MIT's BIH Arrhythmia database. After spectral analysis it was apparent that the between approximately .5Hz-20Hz arrhythmic behavior differentiated itself from normal sinus rhythm spectral characteristics. Therefore, the signal segment was filtered by a digital FIR lowpass filter with cutoff frequency of 20Hz and a digital highpass filter with a cutoff frequency of .5Hz. This is only for arrhythmia detection to preserve the desired signal characteristics in this specific bandwidth. Now after this stage of filtering, analysis was again performed on the spectrum of the signals and it was determined that there was not any specific peaks at any specific frequency. However, there tended to be concentrations of energy in small frequency bands for arrhythmias compared to normal sinus rhythm signals. This resulted in a sub-band total power approach to detecting the arrhythmias. For each tested signal segment the power spectral density of each segment is calculated. Then in sub-bands of 2Hz the total power content in every 2Hz is determined. Afterwards a ratio comparing the power of the tested sub-band versus the characteristic normal total power is calculated. A peak detection algorithm is then implemented to determine if any peak ratios in the tested segment occur above the threshold frequency for arrhythmic activity.

Another component of the detector is a waveform morphology analysis in the time domain signal. This again employs a peak detection algorithm but this time determines the length in time between successive peaks. Arrhythmias tend to be characterized by wider intervals between peaks in their time domain waveforms.

Lastly, a method based on clinically derived QRS complex characteristics of arrhythmias can be employed in conjunction with the QRS complex detection algorithm results to accurately detect arrhythmia. Accuracy is key because in a clinical setting it is important to have as few false alarms and missed alarms as possible, while still maintaining high accuracy. Therefore, a combination of all three approaches will most likely result in the most accurate detections. The detector will be analyzing a new segment of the ECG signal every 5 seconds. The

main purpose of the algorithm is to detect any arrhythmia occurring in the patient versus differentiating between the different types of arrhythmias. Therefore the algorithm is more general in this approach.

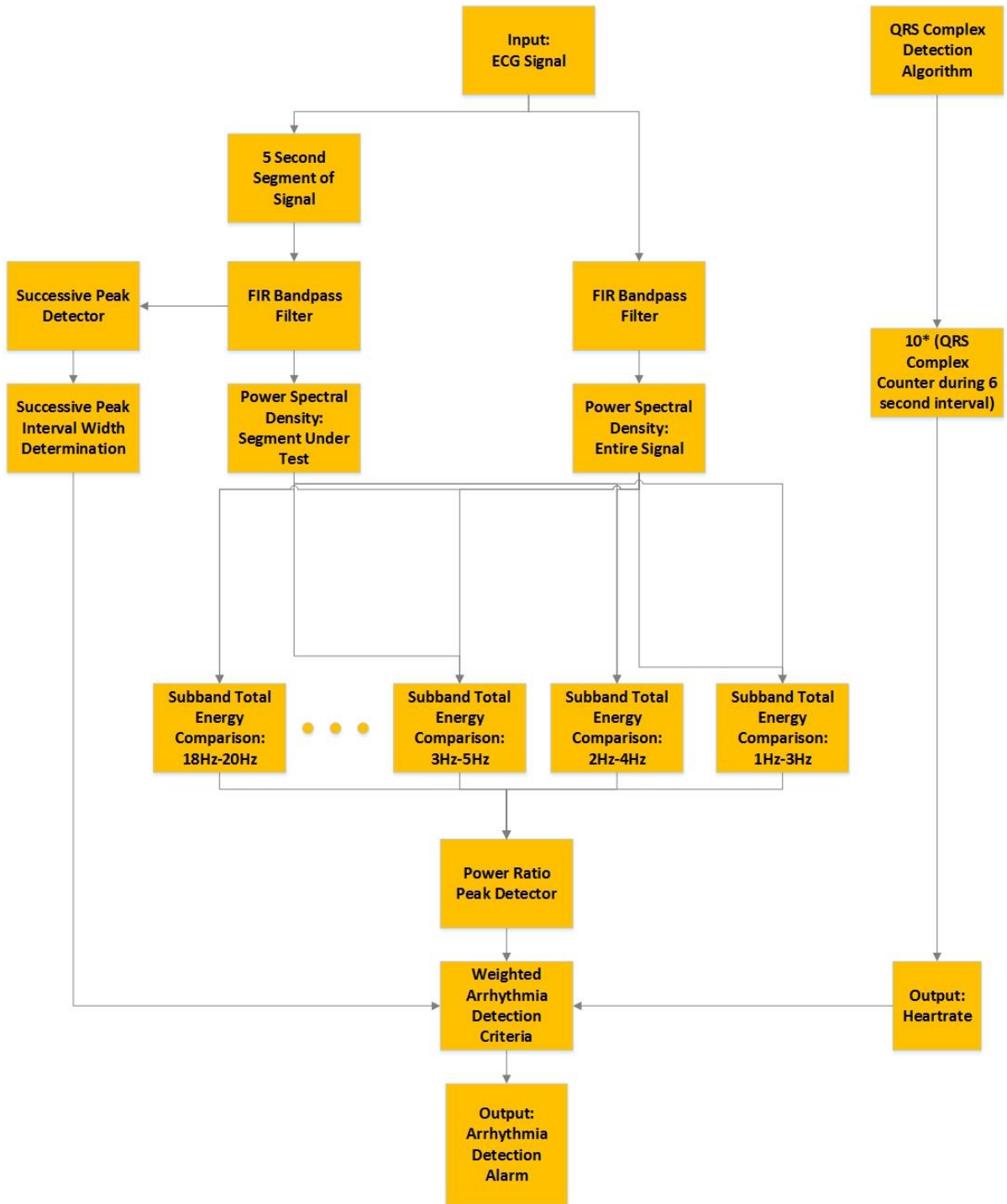

Figure 5.4.2.3- Overview of the ventricular detection algorithm

5.5 ECG Signal Requirements

To obtain a useable signal from the body that accurately depicts the electrical activity of the heart there are many factors that must be taken into consideration. The number of leads must be taken into account as well as the useable bandwidth and overall gain of the system as they are all important factors in achieving an accurate signal to depict the heart's electrical activity.

Leads	1
Electrodes	2
Bandwidth	.5 Hz to 100 Hz
Gain	1000
Analog to Digital converter resolution	16 bits
CMRR	≥ 90 dB

Table 5.5 -Specification targets in terms of the signal.

5.6.1 Leads

ECG leads are the angles at which the spread of electrical activity of the heart are measured. Leads are typically taken as the potential difference of positive and negative poles measured by electrodes put on various parts of the body. The more leads used allows for more data collection. Typically a three lead system is used implementing Einthoven's triangle to position three electrodes on different limbs to form an inverted triangle with the heart at the center of it. A system using three leads places an electrode on each arm to form the top side of Einthoven's triangle and a third electrode on the leg for two more leads to form the two bottom sides of the triangle. Summing together the potential differences from each lead should produce a zero potential. **Figure 5.6.1** shows the forming of Einthoven's triangle with three leads on a body along with the typical signals found at those leads.

In the WVECG design a single lead will be utilized by taking the potentials from the right and left arms using the wristbands. The two potentials will be discretized and sent wirelessly to a central processing hub where they will be used by an instrumentational amplifier to take the difference of the two potentials giving out a readable signal. Typically silver-silver chloride electrodes are used to create a bio potential at the point of contact on the skin.

Standard ECG lead wires will be used to run the signal from the electrode to the analog front end to be filtered. The use of standard ECG lead wires will eliminate the need for us to take shielding into account as unshielded wires act as an antennas picking up electromagnetic interference from other devices in the vicinity.

The standard leads are also already fitted with a clip that snaps onto medical grade electrodes thus making it convenient to incorporate into the WVECG design.

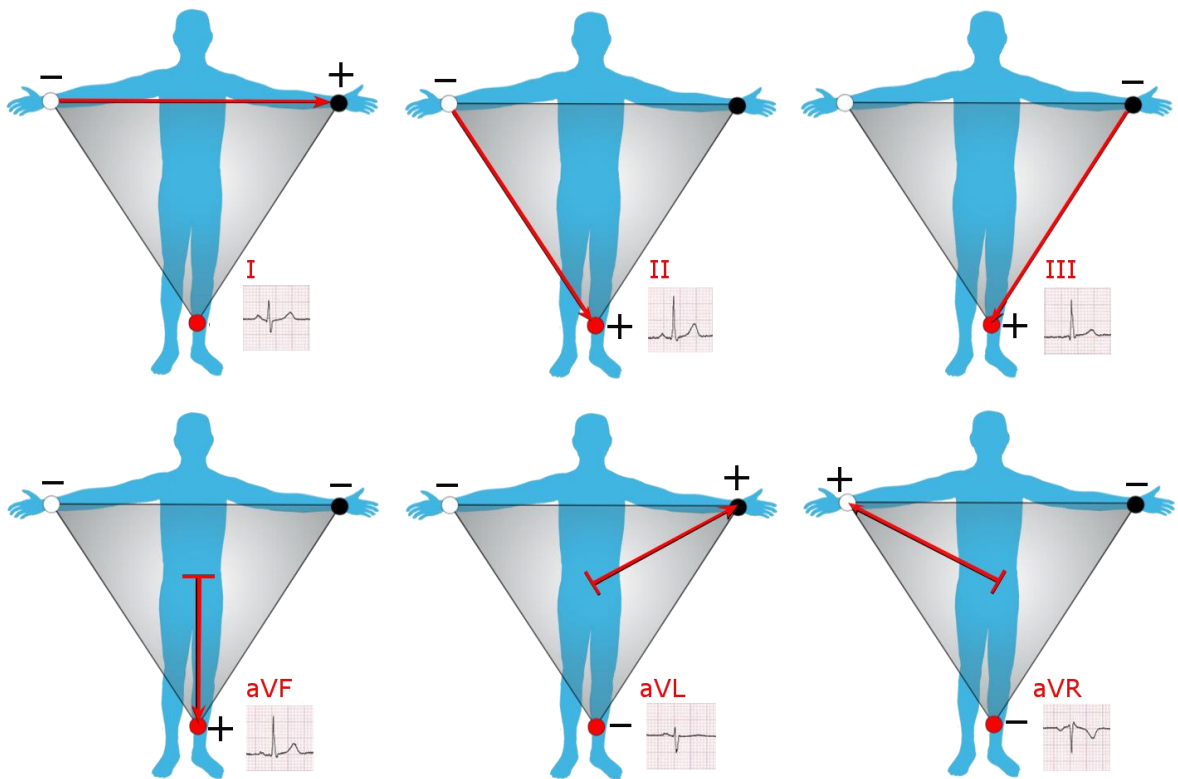

Figure 5.6.1– Einthoven's triangle

5.6.2 Bandwidth

Bandwidth is a critical component to achieving an accurate ECG signal. By choosing which frequencies to accept and which to reject, the signal can be processed without interference being superimposed onto it from unwanted frequencies. Such unwanted frequencies come from electromagnetic interference caused by nearby electronic devices using electronic components that emit electromagnetic energy as high frequencies as well as additional signals coming from the body in the form of motion artifact noise.

A study of the frequency spectrum done on ECG signals showed that the vast majority of information contained in the ECG signal was confined to frequencies below 100 Hz. Therefore, a bandwidth of 100 Hz is probably adequate for accurate recording of the ECG signal from children, as well as from adults¹. In other cases the upper bandwidth cutoff frequency of 3 decibels (dB) was found to be 150 Hz for diagnostic purposes. The American Heart Association recommends a bandwidth of 150 Hz with a sampling rate of at least 500 Hz for recording ECG

signals. This recommendation meets the Nyquist Theorem for sampling rate which states that the sampling rate must be at least twice the highest analog frequency component. To limit the frequency of the signal to this bandwidth without degrading the amplitude of it, an active high pass filter must be implemented. The WVECG will use a combination of second order and single order high pass filters with 3 dB frequencies of 100 Hz for an attenuation rate of 60 dB per decade. The high attenuation rate of these filters is beneficial in eliminating unwanted frequencies.

On the lower end of the frequency spectrum factors that introduce electrode contact noise must also be taken into consideration and filtered out so they do not skew the accuracy of the signal. Such things as loose contact, motion artifacts, and baseline drift due to respiration all affect the fidelity of the signal. With the exception of movement, all these interferences occur around or below .5 Hz. To limit the frequency of the signal to this bandwidth without degrading the amplitude of it, an active low pass filter must be implemented. A combination of second order high pass filters with 3 dB frequencies of .5 Hz for an attenuation rate of 60 dB per decade will be used.

One specific frequency that falls into the bandwidth requirements for an ECG signal that can typically cause interference is 60 Hz mains noise generated by local power lines. Because this interference occurs at a frequency inside the desired bandwidth it must also be filtered out. To filter out on specific frequency in the analog domain a notch filter must be implemented. A notch filter is a band reject filter whose quality factor is very larger allowing for high attenuation around the specific frequency desired for rejection

5.6.3 Gain

The signals given off by the heart's electrical activity can be detected by placing electrodes on the skin however the signal strength from these electrodes is small. The signal strength in terms of amplitude is normally found to be in the range of 1 to 3 millivolts when display on an ECG device but is found in the microvolts range when coming from the body. Thus for the signal to be read by digital equipment it must first be amplified to a level within the detectable range of the equipment. For the signal to be detected it will need to be amplified from the microvolt range to the millivolt range thus amplifying it by a thousand. With such a high gain it will be important to make sure that any noise caused by the electrodes is filtered out otherwise that noise is also amplified by a gain of one thousand. Given such a high gain the sensitivity of both the signal and noise is greatly increased meaning a tiny motion artifact in the original signal could be represented as a much higher error.

For this amplification an inverting amplifier will be used with a gain ratio of one thousand calculated by the transfer function of the amplifier $H(s) = \frac{R_2}{R_1}$ where $R_2 = 100 \text{ k}\Omega$ and $R_1 = 100 \text{ }\Omega$. The use of an inverting amplifier allows for a simplified gain equation and also inverts a negative signal from filtering stages of the WVECG to a positive signal.

5.6.4 Resolution

Because of the nature of the signal taken from the body, much amplification is needed for digital equipment to be able to use it. The resolution of the sensor will depend on the data conversion. The differences between an ECG being considered standard or high resolution are dependent on a few categories. Of these categories the WVECG meets only one requirement of a high resolution ECG having a 16 bit analog to digital converter.

Standard Resolution ECG	High Resolution ECG
Low digital signal resolution	High signal resolution
ECG signal bandwidth 0 Hz -100 Hz	Wider signal bandwidth of .05 Hz – 300 Hz
8 bit Analog to Digital converter	12 bit Analog to Digital converter
Cannot detect late potentials	Can detect late potentials
Focused on all portions of the signal	Focused on terminal portion of QRS complex and further regions
Key analysis of PR interval, QRS duration, ST segment elevation	Key analysis of QRS duration, RMS40 and LAS40

Table 5.6.4- ECG Resolution Comparison

The desired magnitude of the signal will range between 5V and -5V using a 16 bit data converter per wristband. To achieve a resolution using 16 bits the quantization step size must be calculated. The levels of quantization must be greater than 2 to the power of bits, $2^b \geq L$ where b is equal to the number of bits and L is the level of quantization. The level of quantization is represented by the number of steps of quantization plus one. The number of steps is represented as the maximum magnitude of the range minus the minimum divided by the quantization step size Δ . Manipulating these equations will end in calculating the quantization step size Δ .

$$L = s + 1 \qquad s = \frac{V_{max} - V_{min}}{\Delta} \qquad 2^{16} \geq \frac{5 - (-5)}{\Delta} + 1$$

$$\Delta \geq \frac{10}{2^{16} - 1} \qquad \Delta \geq 1.5259e - 4$$

5.6.5 Common Mode Rejection Ratio

The common mode rejection ratio (CMRR) is measured in decibels (dB) as 20 times the log base 10 of the differential mode gain divided by the common mode gain $20\log_{10}\left(\frac{A_d}{A_{cm}}\right)$. In terms of signal fidelity it is an important parameter for determining the attenuation of any noise entering the system. The instrumentation amplifier chosen for the design of the WVECG is one with a very high CMRR so that it is efficient in eliminating large offset signals. The target goal is to have a CMRR of equal to or greater than 90 dB, which is common among integrated circuit instrumentation amplifiers.

5.7 Signal Acquisition Stage

The signal acquisition stage is the most vital in electrocardiography as the signal must be acquired with accuracy and precision. If the fidelity of the signal is weak, important data can be skewed by noise causing inaccurate readings. The biggest threat to accuracy of a signal is noise. Noise can be caused by a multitude of reasons stretching from impedance mismatching to unwanted signals superimposing on top of the signal in the form of electromagnetic interference.

The process for obtaining a strong signal starts at the electrodes and continues throughout the analog front end. Once a signal is filtered and amplified to a discernible value it can be further processed by the digital back end after being digitized into discrete values. The three main stages that the signal must go through to be considered readable enough for an analog to digital converter to digitize it are amplification, anti-aliasing, and noise filtering.

It had been found through testing that no discernable difference in signal quality can be observed whether the anti-aliasing or noise filtering stages come first. However it is the personal preference of the design team that the amplification stage comes last in the signal acquisition stage.

5.7.1 Anti-Aliasing

The anti-aliasing stage is used to restrict the bandwidth of the signal to a range of .5 Hz to 100 Hz. These cutoff frequencies will be the point in the frequency domain where the signal shall lose its magnitude by 3 dB as the signal is attenuated. The benefit of using an anti-alias filter to cut the bandwidth of the signal to a certain span is that while frequencies of wavelengths outside of the bandwidth still exist, the device will not register them as readable values.

The anti-alias filter shall be comprised of two 2nd order Sallen-Key high pass filters cascaded with two 2nd order Sallen-Key low pass filters with cutoff frequencies of .5 Hz and 100 Hz. The designs shown in figures XX and XX are ones used in prototyping and may have some values adjusted for the final edition of the WWECG including the lower cutoff frequency.

Looking at the transfer function of a Sallen-Key Lowpass the cutoff frequency ω_0 is given as $\frac{1}{RC}$ letting $R_1 = R_2$ and $C_1 = C_2$.

$$H(s) = \frac{1}{1 + C_2(R_2 + R_1)s + C_1C_2R_1R_2s^2}$$

where

$$H(s) = \frac{1}{1 + (\frac{1}{Q\omega_0})s + \frac{1}{\omega_0^2}s^2}$$

and $\omega_0 = 2\pi f$ where ω_0 is the cutoff frequency in radians per second and f is the frequency in hertz. By letting $C_1 = C_2$ and $R_1 = R_2$ the cutoff frequency is simplified to $\frac{1}{RC}$. In the WWECG design most if not all capacitors involved in the op amp circuits are at a constant value of 1 microfarad. Schematic capture for circuitry was done with Multisim.

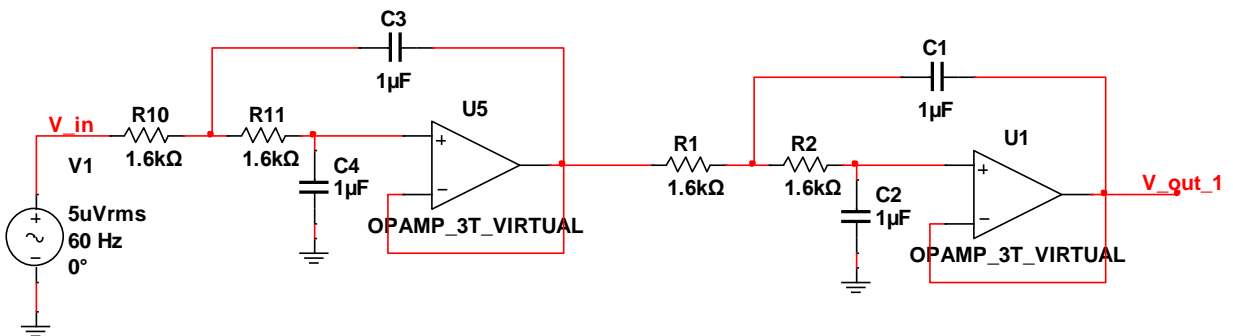

Figure 5.7.1.1 – Two 2nd order Sallen-Key Lowpass filters cascaded

Figure 5.7.1.1 is an AC analysis of the two cascaded lowpass filters. Observing the magnitude graph of the AC analysis shows that the magnitude of the signal starts to attenuate around 50 Hz with its 3 dB cutoff frequency at 100 Hz. The phase graph shows that between 80 Hz and the cutoff frequency of 100 Hz the phase of the signal is reversed as the phase shifts from a negative two hundred degrees to a positive two hundred degrees over the span of 20 Hz. With the two second order filters cascaded the attenuation becomes 80 dB per decade.

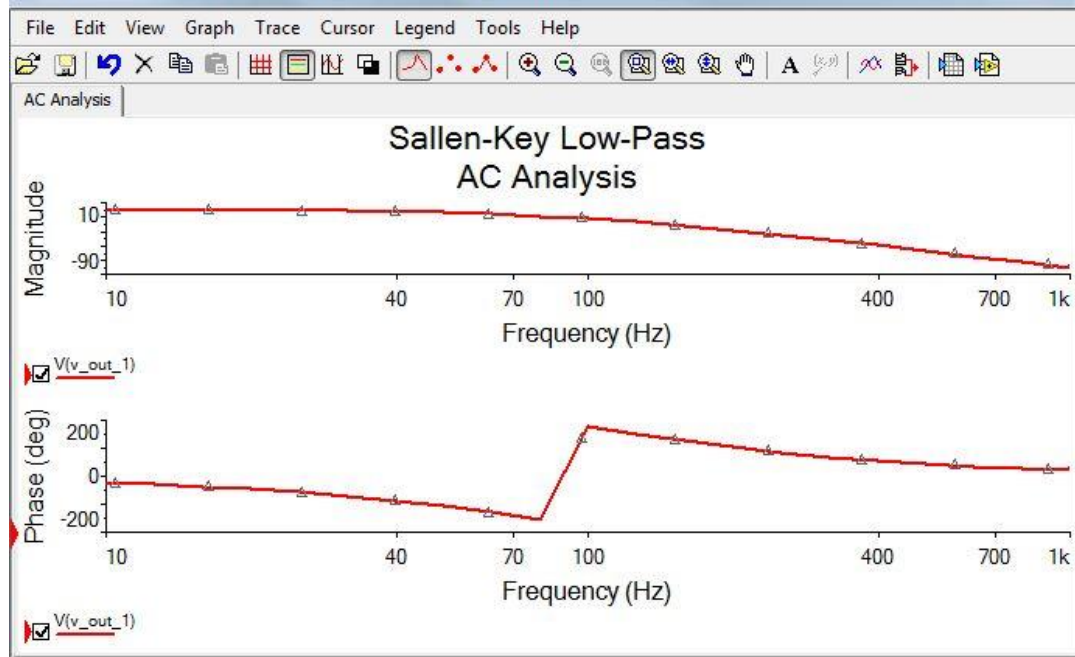

Figure 5.7.1.2– Magnitude and Frequency response of two 2nd order low pass filters

The transfer function of a Sallen-Key high pass is very similar to the low pass. In fact, the only step in changing a Sallen-Key low pass into a high pass is to physically replace the capacitors of the circuit with resistors and the resistors of the circuit with capacitors. The cutoff frequency ω_0 is given as $\frac{1}{RC}$ letting $R_1 = R_2$ and $C_1 = C_2$.

$$H(s) = \frac{s^2 C_1 C_2 R_1 R_2}{1 + R_2 (C_2 + C_1) s + C_1 C_2 R_1 R_2 s^2}$$

where

$$H(s) = \frac{s^2}{1 + \left(\frac{1}{Q\omega_0}\right)s + \frac{1}{\omega_0^2} s^2}$$

and $\omega_0 = 2\pi f$ where ω_0 is the frequency in radians and f is the frequency in hertz. By setting the resistors equal to each other and the capacitors equal to each other the equation for the cutoff frequency is simplified to $\frac{1}{RC}$

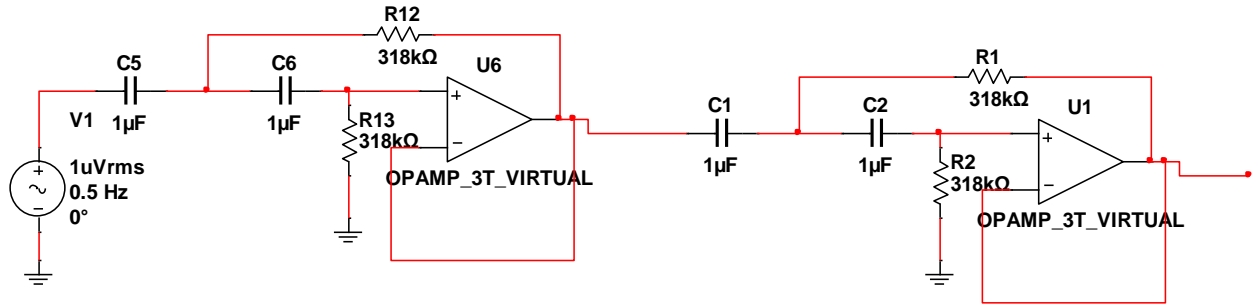

Figure 5.7.1.3– Two 2nd order Sallen-Key Highpass filters cascaded

Figure 5.7.1.4 is the AC analysis in the frequency domain of the two cascaded highpass filters. Observing the magnitude graph of the AC analysis shows the attenuation start around 4 Hz and continues to attenuate until it reaches .5 Hz. There is no signal seen before .5 Hz on neither the magnitude nor phase response graphs. With the two second order filters cascaded the attenuation becomes 80 dB per decade.

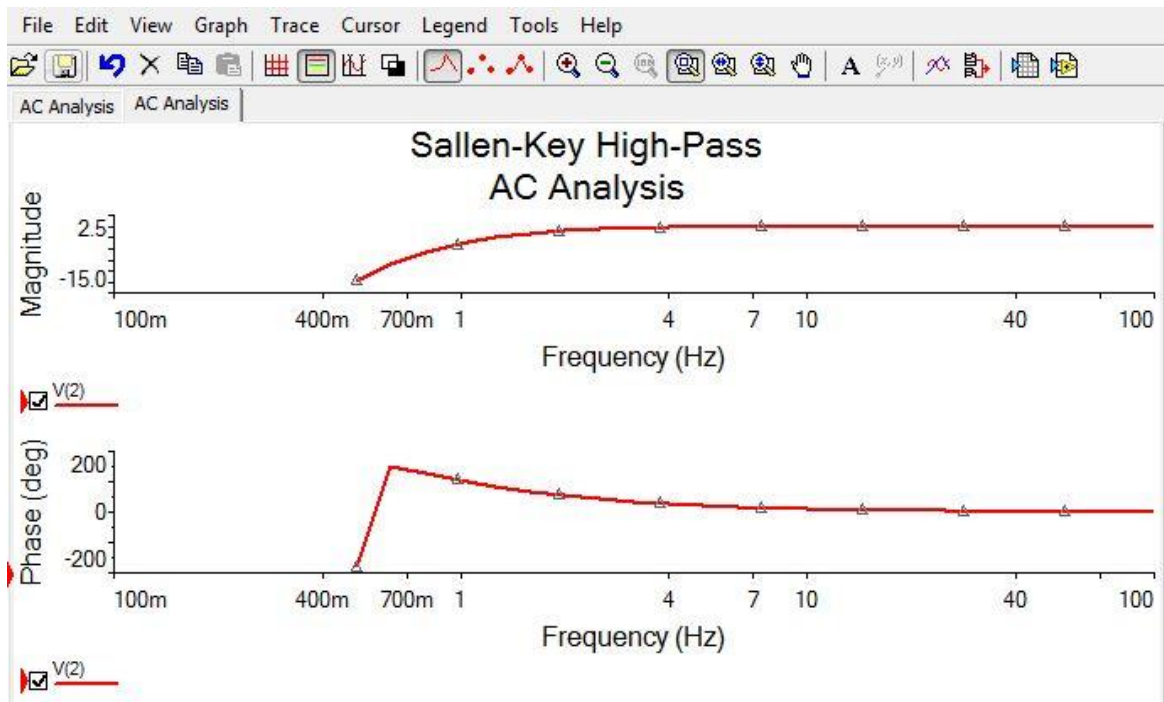

Figure 5.7.1.4– Magnitude and Frequency response of two 2nd order highpass filters

5.7.2 Noise Filtering

The greatest source of noise that falls into the useable bandwidth of an ECG is the mains noise occurring at 60 Hz that comes from local power lines. ECGs use various techniques to rid the system of this noise including the driven right leg

circuit and high gain instrumentation amplifiers. While it is possible to create a band reject filter using a high pass and low pass filter cascaded with each other, it is more convenient to use a different approach. The Tow-Thomas biquad is a useful device for this function, instead of having to make high order high pass and low pass filters with high attenuation rates the Tow-Thomas biquad will allow the implementation of a notch filter by combining it with a summing amplifier.

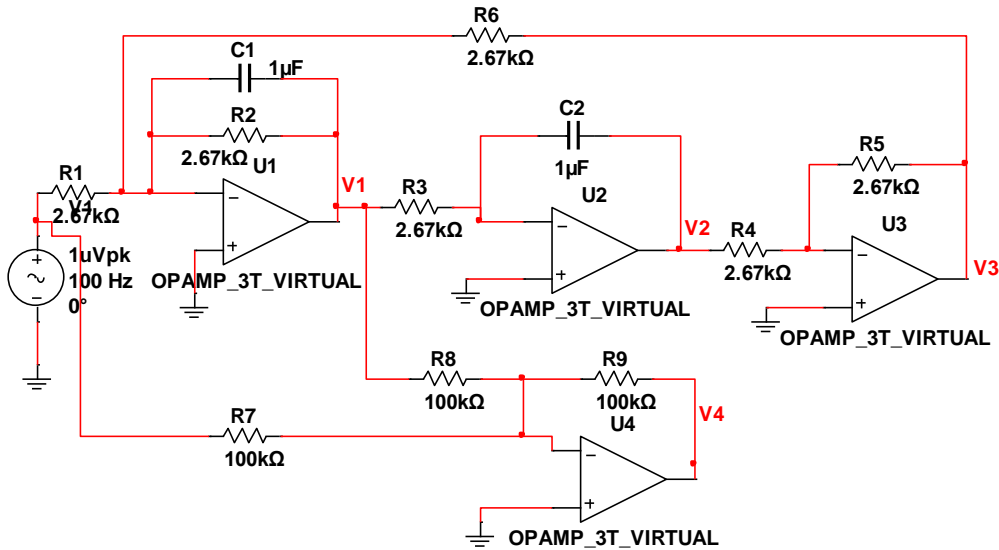

Figure 5.7.2.1– Tow-Thomas Biquad with summing amplifier

Figure 5.7.2.1 shows the Tow-Thomas biquad which has 3 useful outputs located at V1, V2, and V3. The output at the first op amp V1 has bandpass characteristics, the output at the second op amp V2 has lowpass characteristics, and the output of the third op amp V3 acts as an inverting unity gain amplifier.

The cutoff frequency can be determined by $\frac{1}{RC}$ when letting all resistors are equal to each other and all the capacitors are equal to each other. Using 1 microfarad capacitors and setting the cutoff frequency to 60 Hz the resistor value is found to be 2.67 k Ω . By using a summing amplifier to sum the input voltage and the output voltage located the output of the bandpass filter V1 it creates an extremely narrow stopband or “notch” at 60 Hz thus minimizing any interference from local power lines. The resistors of the summing amplifier can be chosen arbitrarily so long as they all match each other in value. 100 k Ω resistors are chosen for convenience of realistic values.

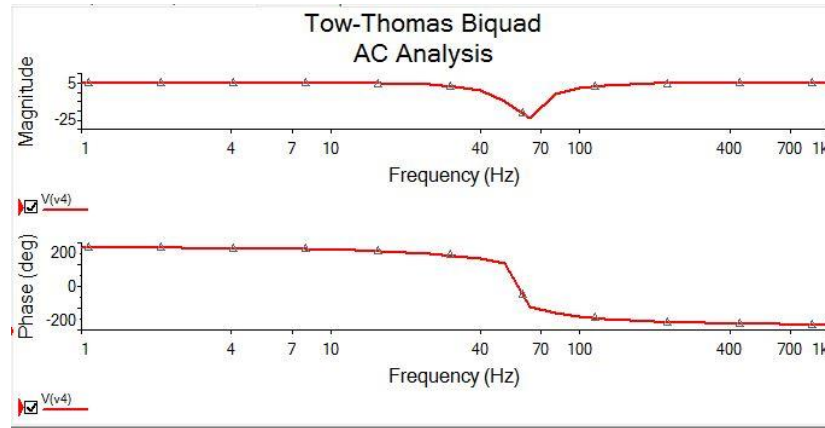

Figure 5.7.2.2– AC Analysis of Tow-Thomas Biquad

As seen in **Figure 5.7.2.2** the magnitude response of the circuit shows a notch at 60 Hz. The phase response shows a phase shift from a positive two hundred degrees to a negative two hundred degrees around the cutoff frequency.

Many of the circuits used for the signal acquisition stage have significant phase shifts. This poses no major concern for this particular application as the sensors will have the same components built in so whatever phase shift one sensor experiences will be experienced by the other as well.

5.7.3 Amplification

Because of the nature of the signal the heart's electrical activity is measured in microvolts, a range that is too small to be used by a digital converter. The signal must be amplified to a range compatible with an analog to digital converter. A simple inverting amplifier will accomplish this.

There are two reasons for choosing an inverting amplifier over a non-inverting one, the first being that before entering the amplification stage the signal is already inverted due to the combination of anti-aliasing and noise filtering stages so the amplifier should invert the signal back. The second reason for choosing the inverting amplifier over the non-inverting is the transfer function. The transfer function of a non-inverting amplifier is $H(S) = \frac{R_2}{R_1} + 1$ while the transfer function of an inverting amplifier is $H(S) = -\frac{R_2}{R_1}$. It is much more convenient in terms of component availability to use an inverting amplifier with a 100 k Ω resistor and a 100 Ω resistor to get a gain of 1000 rather than using the non-inverting amplifier which would need a 9999 Ω resistor over a 100 Ω resistor to get a gain of at least 1000. **Figure 5.7.3.1** shows the schematic for the inverting amplifier.

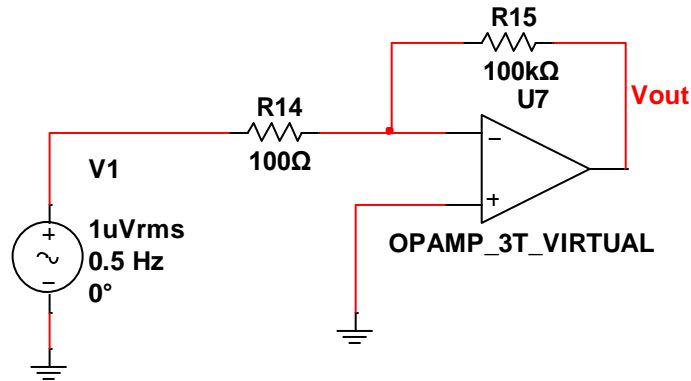

Figure 5.7.3.1 – Inverting Operational amplifier

As shown in **Figure 5.7.3.2**, it can be observed that the inverting op amp has a consistent magnitude throughout the bandwidth concerned with for the WVECG.

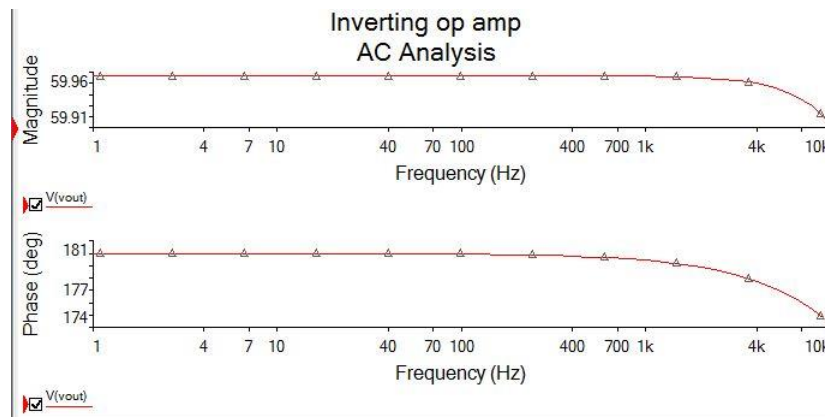

Figure 5.7.3.2 – AC analysis of Inverting Amplifier

When cascaded together, the overall AC analysis of the signal acquisition stage can be represented by **Figure 5.7.3.2**.

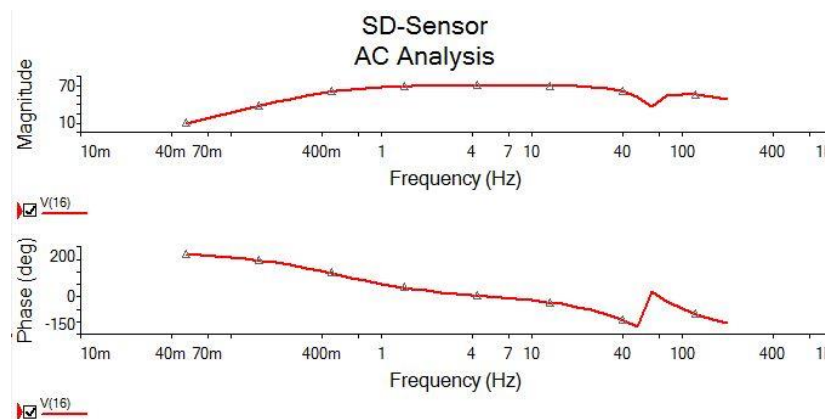

Figure 5.7.3.3– Total AC Analysis of the Sensor

6 Parts and Hardware

The section discusses the specific parts we used to design the hardware and their key aspects.

6.1 Operational Amplifiers

Two different types of operational amplifiers were used for the filter design. One op amp was the TL084 quad JFET-Input Op amp. The TL084 has 4 operational amplifiers built into one integrated chip. The TL084 features high slew rates, low input bias and offset currents. It comes in both a Dual In-line Package (DIP) as well as a Small Outline Integrated Circuit (SOIC) package making it a useful component in using in prototyping as a through hole part as well as the final design as a surface mount part.

The second operational amplifier used was the LF351, a low cost high speed JFET input operational amplifier. This device features low noise and offset voltage drift.

6.1.1 Pin Configuration

TL084

Pin	Name	Pin Description
1	1Out	Voltage Output of 1 st Op Amp
2	1In-	Differential input of 1 st Op Amp
3	1In+	Differential input of 1 st Op Amp
4	Vcc+	Positive Input Power Supply
5	2In+	Differential input of 2 nd Op Amp
6	2In-	Differential input of 2 nd Op Amp
7	2Out	Voltage Output of 2 nd Op Amp
8	3Out	Voltage Output of 2 nd Op Amp
9	3In-	Differential input of 3 rd Op Amp
10	3In+	Differential input of 3 rd Op Amp
11	Vcc-	Negative Input Power Supply
12	4In+	Differential input of 4 th Op Amp
13	4In-	Differential input of 4 th Op Amp
14	4Out	Voltage Output of 4th Op Amp

LF351

Pin	Name	Description
1	Balance	For tuning the op amp
2	In-	Differential input
3	In+	Differential input

4	Vcc-	Negative Power Supply
5	Balance	For tuning the op amp
6	Output	Voltage Output
7	Vcc+	Positive Power Supply
8	NC	No Connection

6.2 DC-DC Converters

The two DC-DC converters being implemented in the WVECG design are the LM2663 CMOS charge-pump voltage converter that inverts a positive voltage to its corresponding negative voltage and the LM2621 low input voltage switching step up DC-DC converter. Both of these chips are being implemented for biasing the dual supply op amps with a positive and negative power supply.

6.2.1 Pin Configuration

LM2663

Pin	Name	Description
1	FC(SD)	External Shutdown
2	Cap+	Positive of the Capacitor
3	GND	Ground
4	Cap-	Negative of the Capacitor
5	Out	Output Voltage
6	LV	Low voltage operation
7	Osc	Oscillation Frequency
8	V+	Positive Power Supply

LM2621

Pin	Name	Description
1	PGND	Power Ground
2	EN	Frequency adjust
3	Freq	Frequency adjust
4	FB	Output Voltage Feedback
5	SGND	Signal Ground
6	Vdd	Positive Power Supply
7	BOOT	Bootstrap Supply for Gate
8	SW	Drain of MOSFET switch

6.3 Texas Instruments TMS320C5535 DSP

For the wireless wearable ECG we are using a digital signal processor to implement QRS detection, heart rate detection, and ventricular arrhythmia detection signal processing algorithms. We have chosen the TMS320C5535 digital signal processor from Texas Instruments because implementing these algorithms via software provides much more flexibility in design compared to implementing via FPGA. Furthermore, the DSP will be housed within the hub/receiver therefore it is important for flexibility in reprogramming it if necessary. This specific model is a high performance low power DSP which is ideal for our application since we are aiming for a portable central hub that will run off of battery. Furthermore its 50-100 MHz clock rate is more than sufficient for this type of application. The peripherals provided by this digital signal processor were also key in deciding to use this model. The TMS320C5535 DSP has a Universal Asynchronous Receiver/Transmitter and Serial Port Interface with four chip selects that will be used to communicate with the embedded processor after processing so the processor can then transmit the data via Bluetooth LE to the user's mobile application. Additionally the TMS320C5535 DSP processor has a tightly coupled FFT hardware accelerator that will be used for computations in certain implemented algorithms. Additionally, this digital signal processor was chosen since it is primarily programmed in C or assembly and uses Texas Instruments' Code Composer Studio Integrate Development Environment.

6.3.1 Central Processing Unit

The CPU's internal bus is constructed of one program bus, one 32-bit data read bus, two 16-bit data read buses, two 16-bit data write buses, and additional buses dedicated to peripherals and Direct Memory Access (DMA) controllers. The multiple buses present the ability to perform up to four data reads and two data writes in a single clock cycle. Additionally, each Direct Memory Access controller has the capability to complete one 32-bit data transfer per cycle, independent and parallel of the CPU activity. In addition, the TMS320C5535's CPU has two multiply-accumulate units that are capable of 17-bit x 17-bit multiplication per cycle. It also sports a 40-bit arithmetic and logic unit that is additionally supported by a 16-bit arithmetic and logic unit. Lastly, this model allows for the use of a variable byte width instruction set.

6.3.2 Internal Memory

The TMS320C5535 has On-Chip Dual-Access Ram located in the byte address range 000000h - 00FFFFh. The DARAM in these addresses are composed of eight blocks of 4K words each and each block can perform two accesses per cycle. Furthermore, the DARAM can be accessed by either the internal program, data, or

the Direct Memory Access buses. In addition, the TMS320C5535 has a zero-wait-state ROM as its On-Chip Read-Only Memory. This memory is located at the byte addresses FE0000h - FFFFFFFh and is composed of four 16K-word blocks, that amounts to 128K bytes of total ROM. The C5535 also has SARAM memory made up of 32 blocks of 4K words each. The byte address range for this memory is 010000h - 04FFFFFFh. Each block of SARAM can perform one read or write per cycle and can be accessed the internal program, data, or Direct Memory Access buses. Lastly, the TMS320C5535 has 64K bytes of I/O memory for the memory-mapped registers of its peripherals and system registers. The I/O space is separate from the program and memory space.

6.4 Instrumentation Amplifier

Once the hub has received the signals from each wrist sensor and they have been converted from digital signals to analog signals they need to be processed to produce the desired ECG signal. This processing occurs in the form of a differential amplifier where the two inputs are the two wrist sensor signals. However, a large source of noise in the electrocardiogram is the common-mode noise seen at the input of the body and this can greatly lower the accuracy of the device. Therefore an instrumentation amplifier with a high common-mode rejection ratio is needed to maintain accuracy. The INA333 is a viable solution to this problem because of its common-mode rejection ratio of approximately 100dB.

6.4.1 Texas Instruments INA333

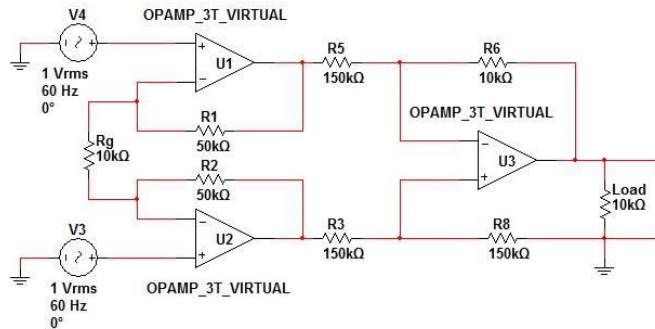

Figure 6.4.1: Configuration of INA333 Instrumentation Amplifier

Pin Configuration:

Pin	Name	Pin Description
1	R _G -1	External resistor for the gain of the amplifier connected to amplifier 1.
2	V _{IN-}	Differential input tied to amplifier 1.
3	V _{IN+}	Differential input tied to amplifier 2.
4	V-	Negative Input Power Supply Voltage
5	Ref	Reference pin normally tied to ground.
6	V _{OUT}	Voltage output
7	V+	Positive Input Power Supply Voltage
8	R _G -2	External resistor for the gain of the amplifier connected to amplifier 2.

6.4.1.1 Gain

The gain of the INA333 is set by an internal resistor R_G, which is connected between pins 1 and 8 of the device. The equation for the gain is

$$G = 1 + 100k\Omega/R_G$$

6.4.1.2 Noise Performance

The INA333 employs an auto-calibration technique for internal offset correction and this technique additionally results in reduced low frequency noise. The low frequency noise typically is around 1μV_{PP} measured from .1Hz to 10Hz at a gain of 100.

6.4.1.3 Input Bias Current Return Path

The INA333 has a very high input impedance at around 100GΩ. This high input impedance makes it so that the input bias current changes very little from its typical value of ±70pA as input voltage varies. Input circuitry must provide a bias return path for proper operation, otherwise the inputs will float to a potential that exceeds the common-mode range of the INA33. Additionally, the input amplifiers will saturate if no bias current return path exists. The bias current return path can be connected to one input if the differential source input is low. Furthermore, if it is a high source impedance two equal resistors can be used to provide a balanced input. This configuration has the advantage of a lower input offset voltage and better high-frequency common-mode rejection.

6.4.1.4 Input Common-Mode Range

The voltage range of the input circuitry for this instrumentation amplifier is approximately 0.1v below the positive supply voltage and 0.1V above the negative supply voltage. The linear common-mode input range is related to the output voltage of the whole instrumentation amplifier. Specifically, the output voltage swing of the first two differential amplifiers in the instrumentation amplifier limits the linear input range.

6.5 Bluetooth Module HM-11 with a Texas Instruments CC2541

The current module we selected is an HM-11 which features a Texas Instruments CC2541 Bluetooth chipset. By using the HM-11 it allows us to easily interface with the UARTs of the microprocessor for communication between the Bluetooth modules and their respective master. This the CC2541 allows us to set the state of each individual model to either a master or slave device. The device features an active RX down power rate of 17.9 and TX down power rate 18.2. The working frequency is the standard Bluetooth and Bluetooth LE radio band of 2.4 GHz. Because the device features the CC2541 it also allows 256kb worth of configurable space with AT command support which allows the state to be set between being a master and slave. The device also has a power supply requirement of 3.3V at 50mA.

6.6 Data Converters

This section discusses the data converters used in the hardware.

6.6.1 Analog to Digital Converter

The Wireless Wearable Electrocardiogram's sensors each take in the users biopotential signal at each limb and transmit the signal via Bluetooth LE to the receiver/hub. In order to transmit the signal it must first be converted from an analog signal to a digital signal. Therefore analog-to-digital converters are employed. We have chosen to use individual ADCs as opposed to the ADCs on the microcontroller because of advantages this model data converter offers.

6.6.1.1 Texas Instruments ADS1114

The ADS1114 is a 16-Bit 880SPS, low-power delta-sigma Analog-to-Digital converter. This ADC operates on a power supply voltage of +2V to +5V. This model was primarily chosen due to its sigma-delta modulation data conversion which

employs oversampling and noise shaping to reduce quantization error in conversion.

6.6.1.1.1 Pin Configuration

Pin	Name	Pin Description
1	ADDR	I ³ C slave address select
2	ALERT/RDY	Digital comparator output or conversion ready
3	GND	Ground
4	AIN0	Differential Channel 1: Positive Input or single ended channel 1 input
5	AIN1	Differential Channel 1: Negative Input or single ended channel 2 input
6	NC	Not Used
7	NC	Not Used
8	VDD	Power Supply: 2.0V to 5.0V
9	SDA	Serial Data: Transmits and receives data
10	SCL	Serial clock Input: Clocks data on SDA

6.6.1.1.2 Analog Input

The ADS1114 uses a fully differential analog input to provide low system noise, around 98db common-mode rejection and high power-supply rejection. There are three main items that affect the performance of this data converter. First, the input impedance can affect the accuracy of the conversion. The input impedance changes with the system clock frequency of the ADS1114. If the source impedance is very high it can affect the accuracy by losing a significant portion of the signal across the external impedance. Secondly, the input or output current needs to be limited for the ADC. Typically this limit is a maximum of 10mA. Lastly, the bandwidth of the analog-input needs to be within half of the system clock frequency to satisfy the Nyquist sampling criteria and avoid signal aliasing. For the purposes of the Wireless Wearable ECG the signal will be sampled at 500 Hz which is much less than the system clock frequency of 8MHz.

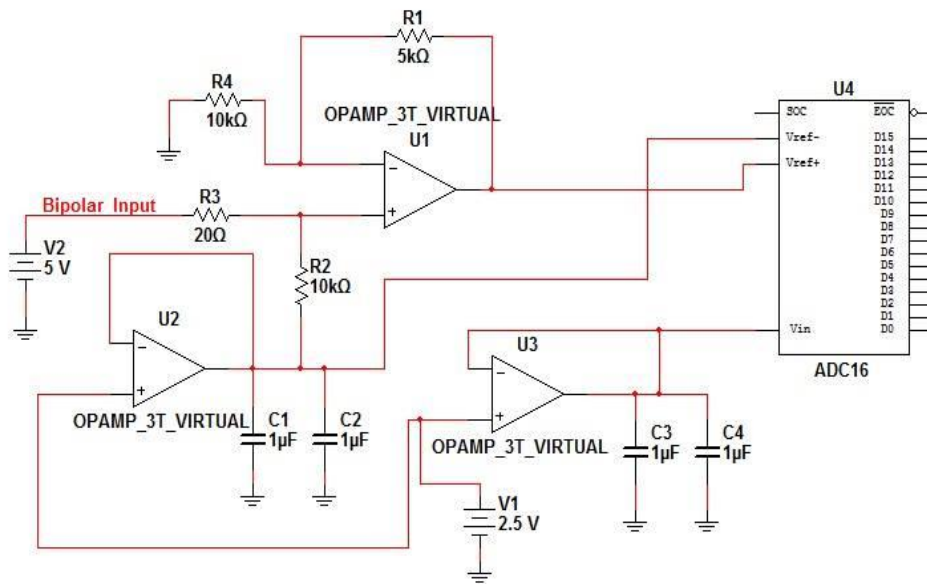

Figure 6.6.6.1.2 Level Shift Circuit for Bipolar Input of $\pm 5V$

6.6.1.1.3 Bipolar Input

The bipolar inputs of the ADS1114 need to maintain a voltage between $-0.3V$ and V_{DD} (Power Supply Voltage). And the reference voltage is normally less than half of the power supply voltage. Typically one input of the ADS1114 is tied to the reference voltage, while the other input falls in the range of $0V$ to $2 \cdot V_{Ref}$. The ADS1251 can be configured to accept bipolar inputs tied to ground by using a 3 op amp circuit with a single amplifier with four external resistors.

6.6.1.1.4 Delta-Sigma Modulator

The main reason this model ADC was chosen was for its delta-sigma modulation functionality. The modulation frequency is equal to taking the system clock's frequency and dividing it by 6. Therefore, the modulation frequency is equal to $1.333MHz$ because the system clock frequency is $8MHz$. The oversampling ratio is 64 and is fixed in relation to the modulation frequency. This results in a $20.8 kHz$ data rate for a modulation frequency of $1.333MHz$ and results in decreasing data output rates for lower system clock frequencies.

6.6.1.1.5 Reference Input

The reference voltage is important in offsetting the output voltage. It is recommended that the reference be buffered for the ADS1114. Additionally, the reference input will take an average input current of $32\mu\text{A}$ with the 8MHz system clock. Reference voltages higher than 4.096V are effective at increasing the full-scale range of the device, while the internal noise of the device stays the same. This results in a decrease of noise and an increase in the effective resolution as well for the ADC.

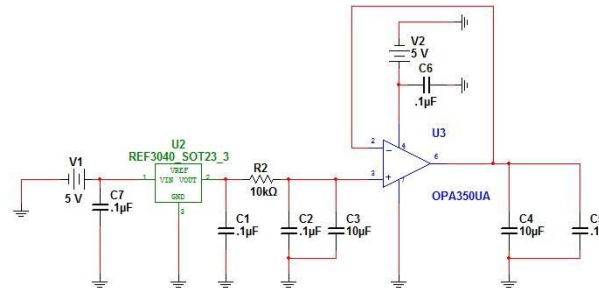

Figure 6.6.1.5.1: External Voltage Reference Circuit for Low Noise Operation of ADS1251

6.6.1.1.6 Digital Filter

The ADS1114 uses a digital filter to compute the digitally converted result based on the most recent outputs from the delta-sigma modulator. The digital output rate scales directly with the system clock frequency. This allows for a good amount of flexibility for the data output range as it can be changed as the system clock frequency changes. However, an important consideration is that the -3db point of the filter is .2035 times the data output rate of the system. Therefore, the data output range should have a sufficient margin so the converted signal does not experience any unwanted attenuation. Since the conversion rate is essentially an average of the outputs, it allows for the ability to use the data output rate in determining the location of notches in the digital filter. Which allows for rejection of not only fundamental frequency but also harmonics of that same frequency. Hereby, implementing a series of notch filters in addition to the desired digital filtering operation. The digital filter requires five conversions before settling and since the modulator has an oversampling ratio of 64 this means that the system requires 320 modulator clocks to fully settle. Since the modulator clock is equal to the system clock divided by six, the digital filter requires $5 \cdot 64 \cdot 6$, or 1920 Clocks,

before settling. Therefore, the analog input requires five full conversions to settle from any significant step change. The transfer function of the digital filter is,

$$|H(f)| = \left| \frac{\sin\left(\frac{\pi \cdot f \cdot 64}{f_{MOD}}\right)}{64 \cdot \sin\left(\frac{\pi \cdot f}{f_{MOD}}\right)} \right|^5$$

or in the Z-domain,

$$H(z) = \left(\frac{1 - z^{-64}}{64 \cdot (1 - z^{-1})} \right)^5$$

6.6.1.1.7 $\overline{DOUT/DRDY}$

The $\overline{DOUT/DRDY}$ output signal alternates between a data ready mode and a data output mode. The data ready mode indicates that new data has been loaded to the output register and is ready to be read. Data output mode serially shifts data out of the Data Output Register. The result of the A/D conversion is written to the Data Output Register from the Most Significant Bit to the Least Significant Bit.

6.7 Digital to Analog Converter

The receiver/Hub of the Wireless Wearable Electrocardiogram will employ an instrumentation amplifier to output the analog ECG signal. However, this requires analog inputs for the differential inputs of the instrumentation amplifier. The wrist sensors each transmit the biopotential signals via Bluetooth, which means the hub receives them as digital signals. Therefore, it is necessary to reconvert the digitally represented signals into the analog domain. Individual Digital-to-Analog converters were used to achieve this need.

6.7.1 Texas Instruments MCP4725:

The MCP4725 is a 14-Bit low-power, single-channel, voltage output Digital-to-Analog converter. They provide high quality linearity and reduce unwanted code-to-code transient voltage. It employs a 3-wire serial interface that operates at clock rates up to 50MHz and is compatible with I2C peripherals. The MCP4725 uses an external power supply as a reference voltage to set the output range. Additionally, the MCP4725 uses a power-on reset circuit to make sure that the DAC output powers up at 0V and stays there until a valid write to the device occurs. Furthermore, the MCP4725 has a power down feature in which the current consumption is reduced to 0.1µA at 2V.

6.7.1.1 Pin Configuration

Pin	Name	Pin Description
1	SDA	Select Data Input this is used to send and receive data between the microcontroller and the MCP4725
2	SCL	Serial Clock Input
3	A ₀	Address select, leave open for address select of 0x63 and jump to V _{DD} for 0x62. This allows for communication between both devices concurrently
4	AV _{DD} /V _{REF}	Power Supply Input, +2V to +5.5V
5	GND	Ground
6	V _{OUT}	Analog Output Voltage from DAC.

6.7.1.2 DAC Architecture

The MCP4725 architecture is made up of a string Digital-to-Analog converter (DAC register followed by Resistor String configuration) followed by an output buffer amplifier. The power supply acts as a reference for the output due to there not being a reference input pin on the device. Since the input coding of the MCP4725 is straight binary the ideal output voltage is,

$$V_{OUT} = AV_{DD} \times \frac{D}{2^n}$$

where n is the resolution size of the data converter, D is the decimal equivalent of the binary code, and AV_{DD} is the power supply input.

6.7.1.3 Resistor String

The resistor string is exactly what its name implies. A string of resistors at value R and the code loaded into the DAC register determines at which node of the string to close the switch and feed the voltage into the output amplifier.

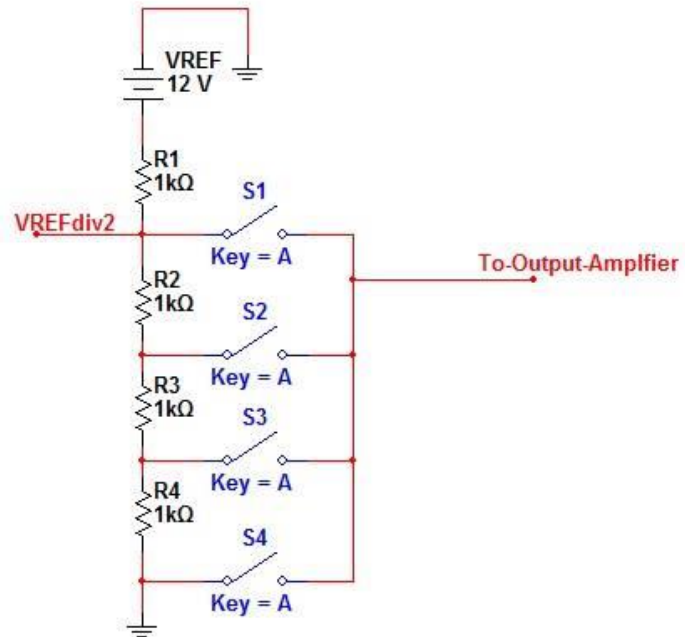

Figure 6.7.3.1: Resistor String configuration in MCP4725 Architecture

6.7.1.4 Output Amplifier

The output amplifier buffer can produce rail-to-rail output voltages which allows the DAC to generate an output range between 0V to the power supply voltage.

6.7.1.5 Power-On Reset to Zero-Scale

The MCP4725 uses a power-on reset circuit to fill the DAC register with zeros on power up and sets the output voltage to 0. The DAC output register will stay at 0 until a valid write sequence is sent to the DAC.

6.8 Microcontrollers

This section gives a brief overview of the microcontroller used for all data movement throughout the system.

6.8.1 Wrist Mounted Microcontrollers

For the wrist mounted microcontrollers we decided to focus on smaller, low power microcontrollers with main purpose of processing the data from electrodes and outputting them to the Bluetooth LE. In order to achieve communication between the devices, the current implementation uses UART peripherals to interphase with each other device since our Bluetooth LE transmission occurs using the

6.8.1.1 Microcontroller Selection

The current microcontroller selected is the Texas Instruments MSP430F5438A which is an ultra-low power microcontroller. The low-power, processing resolution, clock rate, flash memory, ADC conversion resolution, and proper number of UARTS for all of the needed inputs. The other option that was considered when selecting Microcontrollers was the Atmel ATxmega128A1U.

	Power Consumption Active state	Processing clock rate	ADC conversion resolution	Number of UARTS	Flash Memory	Processor Architecture
ATxmega128AU	250uA/MHz	32MHz	12	8	128Kbytes	8-Bit
MSP430F5438A	230uA/MHz	25MHz	12	4	256Kbytes	16-Bit

Table 6.2.1.1 - Comparison between both microcontrollers.

With both processors being quite similar the comparison breaks down mostly to the amount of flash memory, number of UARTS to interface with, and the processor architecture. For this implementation, the memory extra memory within the MSP430F5438A will make development much easier as well as allow space for any expansion in additionally feature if the time allows it. The number of UARTs however favors the ATxmega128AU brought about the necessary amount of UARTs for the project. After determining there was only a need for 4 UARTs maximum with an extra available if needed, the extra 4 UARTs from the ATxmega128AU are not really needed for this given project especially considering the other sacrifices that would need to be made in order to switch chipsets. Overall, while both processors contain many great and similar features and would likely be able to after reviewing the requirements it was decided that the selection be the MSP430F5438A over ATxmega128AU would mostly be due to the 16-bit processing architecture when compared to the 8-bit that that the ATxmega128AU contains. Because the processing needs to be as accurate as possible the 16-bit resolution that the processor could output is the most important feature when comparing both processors. Another helpful feature of the MSP430F538A is the

ability to debug and program without the need for a JTAG programmer or any other proprietary cables other than just a USB as opposed to the ATxmega128AU which needs both a JTAG and aWire for debugging purpose.

6.8.1.2 Power Consumption

One of the main reasons that we chose this microcontroller as opposed to other options is the overall power consumption. The device features a low supply voltage range from 3.6 to 1.8V, 230uA/MHz active state consumption, and 3.0V during flash programmed execution. This consumption rate allows the devices to meet the hour runtime requirement while also being able to handle of necessary processing aspects needed for frequency and resolution of the transmission.

6.8.1.3 Peripheral Communications

Featuring four Universal Serial Interface connections or USCI, the MSP430F5438A also has all of the necessary interface connections to receive, transmit and accept inputted data throughout the system. Because Universal Asynchronous Receive/Transmit or UART are simply a type of USCI three of the ports change be modified to utilize UART in order to handle inputs from the local ADC and the Bluetooth LE during initialization as well as the constant transmission to the master of the data that is pulled from the ADC along with the timestamp from the master.

6.8.1.4 Processing

The MSP430F538A contains a 16-Bit RISC architecture with extend clock memory of up to 25MHz. The 16-bit input from the analog to digital converter and combine that with the timestamp. Before transmission, the data will be processed and shifted down to 12 bits in order to allow the timestamp to be added before being sent outputted to the Bluetooth LE and sent to the hub.

6.8.1.5 Timers

Because the MSP430F538A also has two timers, a single timer on each microprocessor will be used for the system clock and will be set at an equivalent clock rate between both timers via the input clock frequency. With these running in the background the timestamp variable will be set from that timer.

6.8.2 Central Hub Microcontroller

For the hub microcontroller we chose to focus on a powerful but still efficient device that could handle both a master and slave node Bluetooth LE peripheral. These

Bluetooth LE peripherals would both require receive and transmit pins for each of the modules. The central hub would also be required to process the data from both wrist mounted sensors and output this value to the Android device where it can be displayed. This processing will need to be done quickly since the inputs from each wrist mounted sensors will be accepted as fast as possible in order to achieve the highest resolution which allows for the clearest rhythm strip possible.

6.8.2.1 Microcontroller Selection

For this section the decision was between the Texas Instruments MSP432P401R and the Atmel ATmegaV-2560 otherwise known as the chipset that is on the Arduino mega. The main deciding factors in determining which controller to use were low-power, processing resolution, clock rate, flash memory, ADC conversion resolution, and proper number of UARTS which is similar to the requirements set for the wrist mounted microcontrollers. The main difference however is the need for more processing power and being able to sacrifice some of the previous ultra-low power requirements for this due to larger battery on the hub. For this project it was determined that the MSP432P401R will be the best microcontroller for the device.

	Power Consumption active state	Processing clock rate	ADC conversion resolution	Number of UARTS	Flash Memory	Processor Architecture
ATMEGAV-2560	50 μ A/MHz	16Mhz	12	4	256Kbytes	16-Bit
MSP432P401R	90 μ A/MHz	48MHz	12	4	256Kbytes	32-Bit

Table 6.2.2.1 – Microcontroller Comparison

As shown by the graph above, both microcontrollers display very similar overall specifications. However for this projects purposes it was determined to go with the MSP432P401R due to its better battery life to processing to clock rate ratio. Another reason that the ATMEGAV-2560 was selected compared to the MSP432P401R is due to the debugging interface that will be used to program the board. Because the MSP432P401R uses JTAG and aWire to in order to interface and the ATMEGAV-2560 uses USB with Arduino, the decision was made easier due to the familiarity with the debugging interfaces.

6.8.2.2 Power Consumption

Having overall power consumption being a key factor for this microcontroller, with a supply voltage range of 1.62 to 3.7V and 90 μ A/MHz active state consumption.

With these specifications the project should be able to run for up to an hour when processing all of the data. Because the transmission will also be constantly transmitting via Bluetooth LE to the Android device to display and store data for the user. The lower processing rate consumption will allow the transmission to occur much more often providing better results to the user.

6.8.2.3 Peripheral Communications

This microcontroller features four Universal Serial Connection Interface which will be utilized to send and receive data as well as process the signal and time differential between the hub and wrist mounted sensors as well as the Android Bluetooth connection. Because the Android device and the hub itself are both required to be a master the hub will feature two separate Bluetooth modules consisting of one slave and one master that will both require two UART pins in conjunction. The microcontroller also features four more Serial Peripheral Interfaces which will be used to send and receive data from the digital to analog converter to be sent through the instrumentation amplifier and resent to the microcontroller for output.

6.8.2.4 Processing

An overall fairly simple process, the main goal of this microcontroller from a processing perspective is to keep the proper data in their correct formats the output the data as fast as possible. Up receiving both signals from the wrist mounted sensors via a master Bluetooth LE module, the data will then be inputted into the proper form for the instrumentation amplifier. Once the data is sent through the instrumentation amplifier it is reprocessed by taking the calculating the difference from returned timestamps of the original input and the new signal created via the instrumentation amplifier. This newly processed data will then be outputted to the second Bluetooth LE slave where it will send the data to the Android device.

7 Software Applications and Database

This section discusses the specifications of the WVECG Server and WVECG Android application.

7.1 WVECG Server Specifications

This section covers the specifications for all server side activities of the Wireless Wearable ECG. The server side component of the system may be referred to as the WVECG Service or the WVECG Server. The server shall be a LAMP (Linux,

Apache, MySQL, and PHP) stack. As seen in figure X.1, the server is broken up into three main components: the API, the MySQL database, and the file storage.

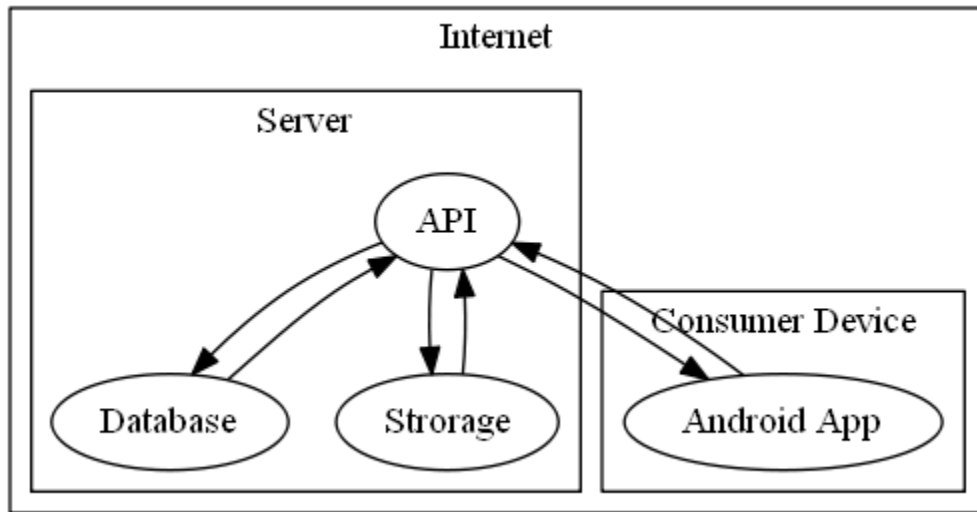

Figure 7.1 - Basic data flow diagram

7.1.1 The Database

The server will use a MySQL database on the server. The database name for this system shall be “wwecg”.

7.1.1.1 Tables

This section contains the documentation for the database tables and their respective columns. Note that UUID Strings will follow the following format: <https://www.ietf.org/rfc/rfc4122.txt> .

7.1.1.1.1 /clients

The /clients table contains all of the client information for the service. For the prototype we will only be storing our Android app’s credentials here. However if desired, more than just the official app’s credentials may be stored here.

Column	Name	Type	Description
1	Id	Integer	The id for the client
2	name	String	The name of the client

3	secret	String	The secret string for authenticating the client
4	is_disabled	Boolean	Will be true if the client has been disabled by an admin A disabled client must not be permitted to authorize

7.1.1.1.2/files

The /files table contains records for all files uploaded to the server.

Column	Name	Type	Description
1	Id	Integer	An id for private reference
2	Uuid	UUID String	The public UUID of the file
3	url	URL String	The URL pointing to the file
4	timestamp	Long Integer	The UNIX timestamp for when the file was created
5	owner_id	UUID String	The UUID of the patient that the file relates to

7.1.1.1.3 /grants

The /grants table contains records that indicate a client's (and potentially) a user's temporary authorization to use the WVECG API and have limited access to the server.

Column	Name	Type	Description
1	id	Integer	An id for private reference

2	access_token	String	The unique string leased to a client for accessing a user's account
3	refresh_token	String <i>NULLABLE</i>	The unique string to renew the access token when the token expires
4	user_id	UUID String	The UUID of the user that this authorization is linked to
5	client_id	Integer <i>NULLABLE</i>	The id of the client this authorization is linked to
6	expires_at	Long Integer	The UNIX timestamp in which the access_token is no longer valid. Typically this should be 3600 seconds after the session is started.
7	is_revoked	Boolean	Will be false unless the refresh_token and the access token are both revoked In the case that a client is disabled, the authorizations linked to that client SHOULD be automatically revoked

7.1.1.1.4 /users

The /users table contains records pertaining to user accounts. This includes the user's credentials for accessing the app as well as personal information.

Column	Name	Type	Description
1	id	Integer	An id for private reference
2	uuid	UUID String	A uuid for public reference of this user
3	name_first	String	The user's first name
4	name_middle	String	The user's middle name

5	name_last	String	The user's last name
6	password	String	A KDF hashed password We will use PBKDF2 with a local salt, a global salt, and an iteration count of 1024. This MUST NOT be exposed by the API and it should only be used to verify user credentials.
7	Salt	String	The local salt for the password KDF
8	Type	Enum String	{ADMIN, BANNED, DOCTOR, PATIENT, USER} Doctors, admins, and banned users must be manually set in the database in the currently designed system. Users of type PATIENT are only to be used with doctor-patient records. They may not be logged into and information may not be attached to them aside from the user_id.
9	email	String	The email address of the user This is essentially the user's username
10	gender	Enum String	The user's gender {MALE, FEMALE, OTHER}
11	birthdate	Long Integer	A UNIX timestamp of the user's birthday

7.1.1.2 Security

This section discusses the security measures used on the database.

7.1.1.2.1 Protected Table Fields

The id fields inside of the database tables MUST NOT to be disclosed via the API. The users' PBKDF'd passwords and salts MUST NOT be disclosed by the API. The client secrets MUST NOT be disclosed by the API.

7.1.1.2.2 Database Access

The database may only be directly accessed by an admin via a direct connection or by the API. The app must not access the database directly, and only via the WVECG Service API. Any non HTTPS attempt to the database MUST either be upgraded to HTTPS or ignored.

7.1.1.2.3 Database Sanitization

Any SQL query MUST be sanitized. This is to prevent unauthorized SQL injections. SQL injections may be trivially be used to read or modify the database so they must be prevented.

7.1.2 The Application Programming Interface

The API is a collection of PHP endpoints that follow the REST (REpresentative State Transfer) paradigm. All endpoints shall support the HTTPS protocol.

7.1.2.1 Limitations and Constraints

This section discusses the limitations and constraints of the API.

7.1.2.1.1 JSON

JSON (Java Script Object Notation) is a common transport container used with RESTful interfaces. While it is commonly used, it has some limitations. The biggest limitation is that it is generally not a streamable data structure, which is ok for its use in the API, as the API is a RESTful and not a streaming API. Any use of JSON requires the code to translate the JSON into a Java object. This constraint is not a tough one to overcome, as one would just have to implement a JSON decode into their classes to decode the JSON structure.

7.1.2.1.2 REST

REST (REpresentative State Transfer)'s biggest constraint is that it does not allow for the streaming of data. This means live processing of WVECG session data is not able to be done on the server side and must be done on the client side. However, REST will be perfect the post processing of WVECG sessions that are uploaded to the WVECG Server.

7.1.2.2 Authentication and Security

The API's authentication model is documented in RFC 6749 (The OAuth 2.0 Authentication Framework <https://tools.ietf.org/html/rfc6749>). As such, the endpoints MUST use the HTTPS Protocol. Figures 2 and 3 show a complete and a simplified authentication flow for the API. This implementation of OAuth2 includes the /token "grant_type" parameters of: password, refresh_token, and client_credentials. This will allow for first party user authentication and client authentication. The server may use a self-signed or a CA-signed security certificate.

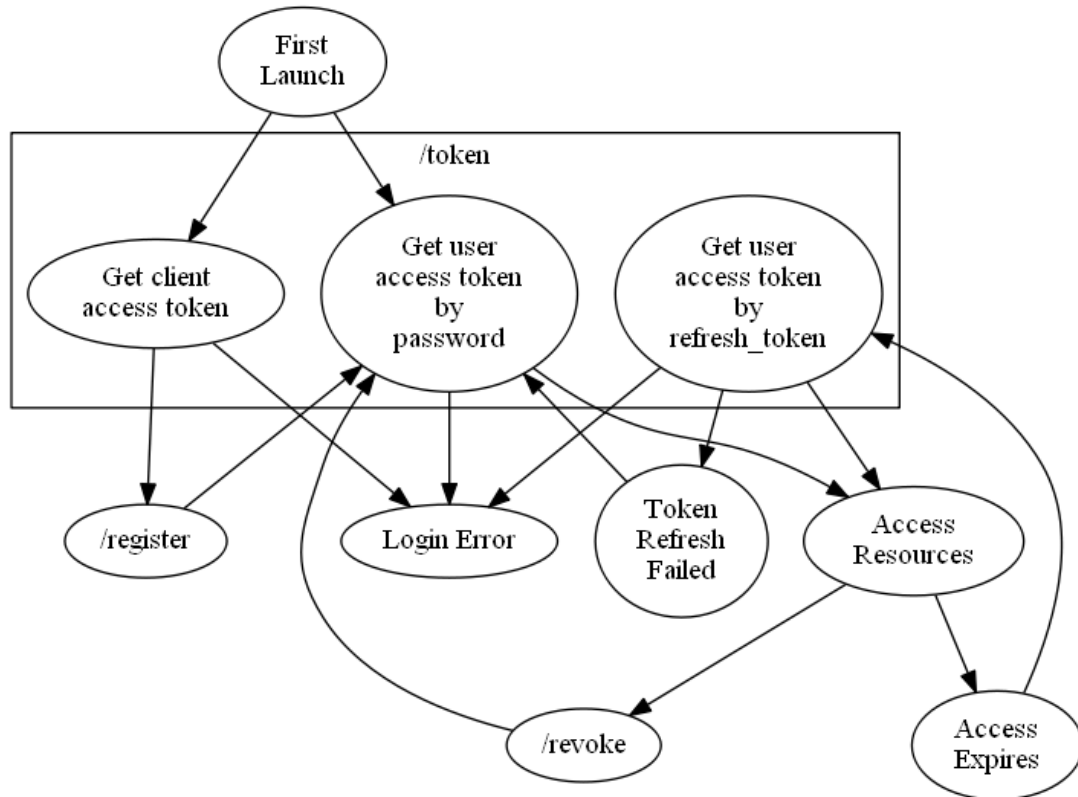

Figure 7.1.2 - Authentication Flow

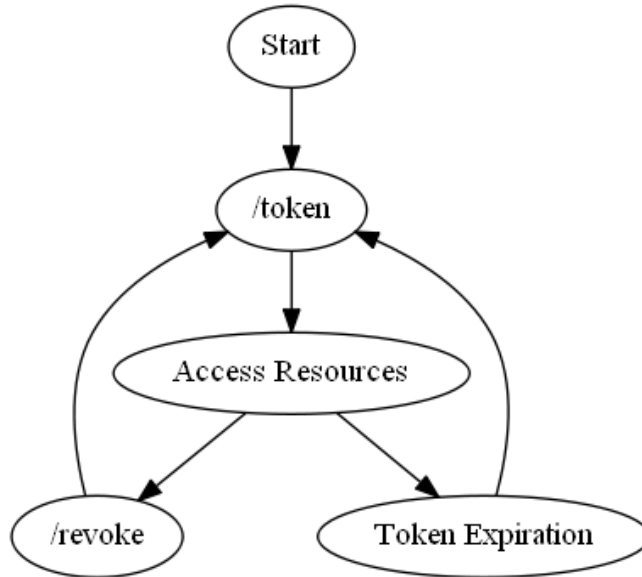

Figure 7.1.3 - Simplified Authentication Flow

7.1.2.2.1 Scopes

For the sake of simplicity, this implementation of OAuth2 will not include access request scopes.

7.1.2.2.2 Errors

API errors will contain both a HTTP response code and a JSON formatted message describing the error that occurred.

7.1.2.3 HTTP Codes

This table includes the HTTP response codes the server may implement and how they should be interpreted by the Android client.

HTTP Response Code	Description
200	The request was successful.
400	The request failed due to a client error (e.g. User not found).

429	Rate limit exceeded. This response will likely not be utilized in this prototype.
500	Our servers encountered an internal error, try again.
503	Our servers are currently unavailable, try again later. This may be caused by server maintenance. This response will likely not be utilized in this prototype.

7.1.2.3.1 JSON Error Format

The JSON format for API errors is as follows:

```
{
  error (Enum String)
  description (String)
  details (array [Key-Value Pairs]) Optional
  code (Integer) Optional
}
```

Example:

```
{
  "error": "invalid_request",
  "description": "Request field validation failed.",
  "details": [
    "username": "username is required",
    "password": "password is required"
  ],
  "code": 2
}
```

7.1.2.3.2.1 Error Enumerations

Error this table includes the values that an error may set as it's "error" field and their respective descriptions of how they should be interpreted by the client.

Name	Description
invalid_request	General Error
unauthorized	Access denied to an endpoint or one of its resources
server_error	Server error, try again later

7.1.2.4 Versioning

As this is a prototype API not intended for a publicly released product, API versioning features will not be included for the sake of simplicity.

7.1.2.5 Endpoints

Note that for all except for /token, an “access_token” parameter MUST implicitly be sent with the request. The “access_token” parameter may be sent as a GET or a POST parameter. All endpoints with the exception of /ecg/file will provide a JSON response in the HTTP response body. The JSON responses will include an implicitly included status field (of type String) that must either be “success” or “error”.

7.1.2.5.1 /admin

This section of the API contains admin restricted endpoints. For now, this API section is reserved for potential future use. If a non-admin user attempts to access these endpoints, the server should not fulfil the request and it should instead reply with a HTTP 400 response code and the following JSON message:

```
{
  "status": "error",
  "error": "unauthorized",
  "description": "User is not an admin."
}
```

7.1.2.5.2 /auth

This section of the API includes endpoints for the client and user authentication with the API. This section also contains some authentication utilities such as /auth/register which will allow the user to create a new account.

7.1.2.5.2.1 /placebo

The /auth/placebo endpoint is used to verify that the client/user’s access token is still valid.

GET /auth/placebo	Will give a successful status if the access_token is valid
Authorization	User or client credentials access grant
Response	{ }

7.1.2.5.2.2 /register

The /auth/register endpoint is used to create a new user account. The account type will be “PATIENT”.

POST /auth/register	Create a new patient account	
Authorization	Client credentials access grant	
Parameters	POST firstname (String)	The user’s first name
	POST middlename (String)	The user’s middle name
	POST lastname (String)	The user’s last name
	POST birthdate (Long Integer)	A UNIX Timestamp of the user’s birthday

	POST gender (Enum String)	The gender of the user
	POST password (String)	The user's desired password
	POST email (String)	The user's email address
Response	<pre>{ (Grant Object) }</pre>	
Error Codes	1	Weak password
	2	Illegal password
	3	Email taken

7.1.2.5.2.3 /revoke

The /auth/revoke endpoint will revoke a /grant record.

POST /auth/revoke	Revoke the /grant records	
Authorization	User access grant	
Parameters	POST access_token (String) <i>Optional</i>	A nonrevoked, nonexpired access_token to revoke. If an access_token is provided, do not provide a refresh_token.
	POST refresh_token	A nonrevoked, refresh_token to revoke.

	(String) <i>Optional</i>	If an access_token is provided, do not provide a access_token.
	POST revoke_all (Boolean) <i>Optional</i>	If this is true, all /grant records of the user that the token belongs to. default: false
Response	{ }	
Error Codes	1	Provide an access_token OR a refresh_token, not both.
	2	Cannot revoke all grants if the grant type of the /grant record is "client_credentials".

7.1.2.5.2.4 /token

The /auth/token endpoint is used to get a new /grant record, which includes an access_token and a refresh_token. The "access_token" parameter is NOT an accepted parameter for this endpoint. All responses will include a token_type of "Bearer".

7.1.2.5.2.4.1 Obtaining a Client Credentials Grant

Use this version of /auth/token to get a client_credentials grant.

POST /auth/token	Authorize the app to access the user's account	
Parameters	POST client_id (Integer)	The client's id
	POST client_secret (String)	The client's secret
	POST grant_type (Enum String)	The value must be "client_credentials"

Response	{ (Grant Object) }	
Error Codes	1	Client is disabled
	2	Invalid client credentials
	3	Invalid grant_type

7.1.2.5.2.4.2 Obtaining an User Access Token

Use this version of the /auth/token to get a new user grant from the user's credentials.

POST /auth/token	Authorize the app to access the user's account	
Parameters	POST client_id (Integer)	The client's id
	POST client_secret (String)	The client's secret
	POST grant_type (Enum String)	The value must be "password"
	POST email (String)	The user's email address
	POST password (String)	The user's password The app MUST forget the user's password after a successful response for security reasons
Response	{ (Grant Object) }	

	}	
Error Codes	1	Client is disabled
	2	Invalid client credentials
	3	Invalid grant_type
	4	User is banned
	5	Invalid user credentials

7.1.2.5.2.4.3 Refreshing an User Access Token

Use this version of the /auth/token endpoint to get a new user grant from the provided refresh_token.

POST /auth/token	Authorize the app to access the user's account	
Authorization	User access grant with refresh token	
Parameters	POST client_id (Integer)	The client's id
	POST client_secret (String)	The client's secret
	POST grant_type (Enum String)	The value must be "refresh_token"
	POST refresh_token (String)	The user's refresh_token
Response	<pre>{ (Grant Object) }</pre>	
Error Codes	1	Client is disabled

	2	Invalid client credentials
	3	Invalid grant_type
	4	User is banned
	5	Invalid refresh_token

7.1.2.5.3 /data

This set of endpoints is used to get basic static details about the Android app / WVECG service.

7.1.2.5.3.1 /privacy

The /data/privacy endpoint is used to retrieve the WVECG Privacy Policy.

GET /data/privacy	Retrieves the service's Privacy Policy
Authorization	User or client credentials access grant
Response	{ body (String) }

7.1.2.5.3.2 /tos

The /data/tos endpoint is used to retrieve the WVECG Terms of Service.

GET /data/tos	Retrieves the service's Terms of Service
Authorization	User or client credentials access grant
Response	{ body (String) }

7.1.2.5.4 /ecg

The /ecg category of endpoints is a suite of specialized endpoints for the WVECG service.

7.1.2.5.4.1 /file

The /ecg/file endpoint is used to retrieve a specified file of the authenticated user or a doctor's patient.

GET /ecg/file	Retrieves a specified file	
Authorization	User access grant	
Parameters	GET file_id (UUID String)	The UUID of the desired file. If the file does not belong to the authenticated user and the user is not a doctor or an admin, the request should fail with code 1.
Response	(File)	
Error Codes	1	Unauthorized
	2	Invalid file_id

7.1.2.5.4.2 /files

The /ecg/files endpoint is used to retrieve a list of files that the authenticated user or a doctor's patient owns.

GET /ecg/files	Retrieves the files associated with a patient	
Authorization	User access grant	
Parameters	GET user_id (UUID String) <i>Optional</i>	The UUID of the desired patient. If a UUID is not provided it will use the UUID of the currently authenticated user.

		If the requesting user is not a doctor or an admin, the request will fail.
	GET offset (Integer) <i>Optional</i>	The pagination offset min: 0 max: 100,000 default: 0
	GET limit (Integer) <i>Optional</i>	The pagination offset min: 1 max: 100 default: 10
Response	<pre>{ has_more (Boolean) results (array [File Object]) }</pre>	
Error Codes	1	Unauthorized
	2	Invalid user UUID
	3	Invalid offset
	4	Invalid limit

7.1.2.5.4.2 */newpatient*

The `/ecg/newpatient` endpoint is used to link the user to a doctor or to unlink the user from a doctor.

POST <code>/ecg/newpatient</code>	Creates a new patient record for the doctor. The patient record is just a random UUID. It creates a new user record that has no personal information attached to it.
--------------------------------------	--

Authorization	User access grant The authenticated user must be an admin or a doctor An admin will retrieve all users in the system	
Response	{ (User Object) }	
Error Codes	1	Unauthorized

7.1.2.5.4.3 */linkdoctor*

The `/ecg/linkdoctor` endpoint is used to link the user to a doctor or to unlink the user from a doctor.

POST <code>/ecg/linkdoctor</code>	Links a specified doctor to the authenticated user account	
Authorization	User access grant	
Parameters	POST <code>doctor_id</code> (UUID String)	The UUID of the doctor. If the <code>doctor_id</code> is “null”, then the user should no longer be linked to a doctor. If the <code>doctor_id</code> does not belong to the doctor, the request should fail with either code 1 or 2 depending on the situation.
Response	{ }	
Error Codes	1	Invalid <code>doctor_id</code>
	2	The <code>doctor_id</code> does not belong to a doctor

7.1.2.5.4.4 /patients

The /ecg/patients endpoint retrieves the patients of the currently authenticated doctor. If the current user is not a doctor, then this call will fail.

GET /ecg/patients	Retrieves the patients of the currently authenticated doctor	
Authorization	User access grant The authenticated user must be an admin or a doctor An admin will retrieve all users in the system	
Parameters	GET offset (Integer) <i>Optional</i>	The pagination offset min: 0 max: 100,000 default: 0
	GET limit (Integer) <i>Optional</i>	The pagination offset min: 1 max: 100 default: 10
Response	{ has_more (Boolean) results (array [User Object]) }	
Error Codes	1	Insufficient privileges
	2	Invalid user UUID
	3	Invalid offset
	4	Invalid limit

7.1.2.5.4.5 /upload

The /ecg/upload endpoint retrieves enables users to upload WVECG sessions to the WVECG Service. If necessary, this endpoint may be designed to delegate post processing of WVECG sessions. In this case it will alter the file and essentially make annotations in the file to mark metrics and features of the WVECG session. Metrics and features may include: beats per minute, identification of the Q, R, and S peaks, identification of atrial fibrillation, and identification of irregular heartbeat.

POST /ecg/upload	Retrieves the patients of the currently authenticated doctor	
Authorization	User access grant If the authenticated user is an admin or a doctor, they can store the WVECG Session on the behalf of a patient.	
Parameters	POST patient_id (UUID String) <i>Optional</i>	The patient's UUID to store the file on behalf of. If the authenticated user is not an admin or a doctor, a code 1 error should be issued.
	(Multi-Part Form Data)	A binary file of the WVECG session.
Response	{ (File Object) }	
Error Codes	1	Unauthorized
	2	Invalid user UUID
	3	Invalid file
	4	Processing error

7.1.2.5.5 /user

The /user category of the API is for endpoints used to get information of users.

7.1.2.5.5.1 /whoami

The /user/whoami endpoint gives the client information about the currently authenticated user.

GET /user/whoami	Retrieves the currently authenticated user's information
Authorization	User access grant
Response	{ (User Object) }

7.1.2.6 Data Objects

This section describes the commonly used JSON objects mentioned in section 7.2.5.

7.1.2.6.1 File

The File object contains meta information on a file on the server. This is the client facing representation of a /file record.

```
{  
  id (UUID String)  
  file (URL String)  
  patient (UUID String)  
  timestamp (Long Integer)  
}
```

7.1.2.6.2 Grant

The Grant object is the client facing representation of a /grant record.

```
{
```

```
    access_token (String)
    refresh_token (String) Optional
    expires_in (Integer)
    token_type (Enum String)
}
```

7.1.2.6.3 User

The User object is the client facing representation of a /user record.

```
{
    id (UUID String)
    email (Email String) Optional
    name_first (String)
    name_middle (String) Optional
    name_last (String)
    gender (Enum String) Optional
    birthdate (Long Integer) Optional
    doctor (User Object) Optional
    type (Enum String)
}
```

7.1.2.6.4 Storage

The files uploaded to the server will be stored in the /var/wwecg/ directory on the machine running the backend server. All WVECG sessions stored in this directory must be encrypted with the AES 256-bit key. The files will be decrypted by the server prior to sending it to the client. However, a TLS tunnel will be in use so the file will remain secure.

7.2 WVECG Client Specifications

This section entails the specifications of the Android client to be used with the WVECG. The app will be compatible with Android 5.0 (Lollipop) and up. The app will be designed with Google's Material Design Guidelines in mind. Figure X.1 includes a class diagram of the client side portion of the system.

7.2.1 Screens

This section entails the specifications of each screen of the application. These specifications include: The screen name, on-screen components, user actions, the activity's parent activity, and general details explaining what the screen's main functions are. For simplicity, the words 'Screen' and 'Activity' will be used interchangeably in this section, but as a developer's note: A 'Screen' is a layout or a collection of UI layouts that make up an activity's UI, while an activity is a microprogram that controls the screen UIs. For this app, each screen will map to one activity.

7.2.1.1 Login Screen

This is the first activity that will launch with the app is started. The purpose of the Login Screen is to enable the user to login to the WWECG Service

Type	ID	Description
EditText	txtUsername	A textbox for collecting the user's username.
EditText	txtPassword	A textbox for collecting the user's password. The contents of this box should be hidden.
Button	btnLogin	A button that will attempt to log the user into the WWECG service. Upon failure, a Toast with an error message will be displayed. Upon success, the Login Activity will close and return to the Start Screen where the start screen will close and launch the Link ECG Activity.

Table 7.2.1.2 - Start Screen UI Components

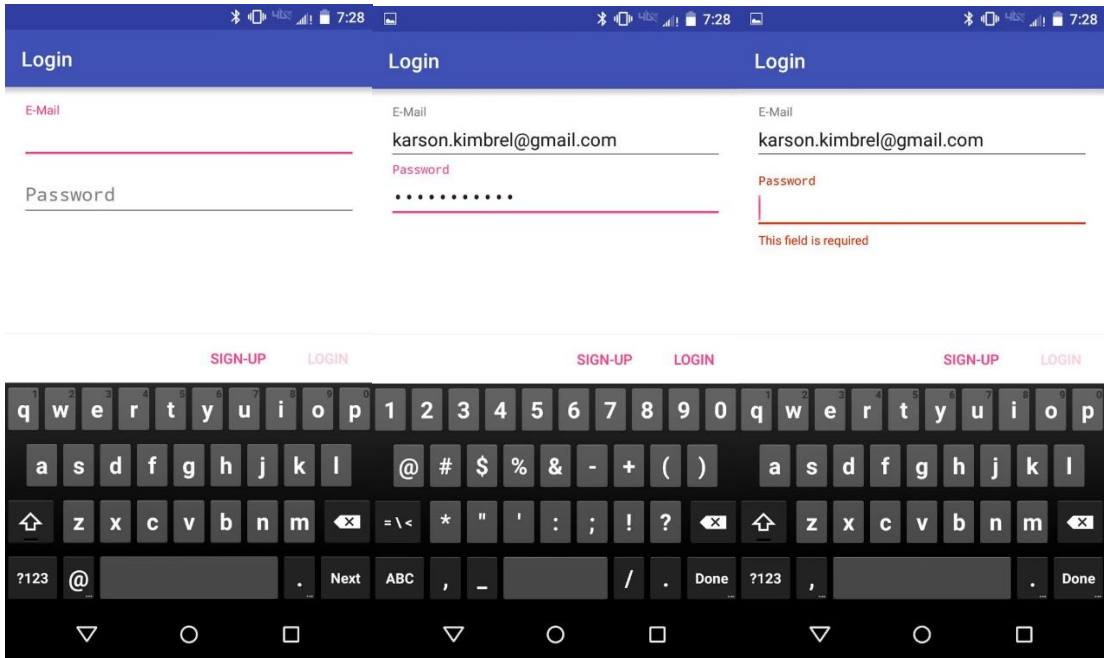

7.2.1.2 Register Screen

The Register Screen is used by the user to create a new account for the WVECG Service. The Register Activity is accessible from the Start Screen. The parent activity of the Register Activity is the Login Activity.

Type	ID	Description
EditText	txtUsername	A textbox for collecting the user's username.
EditText	txtPassword1	A textbox for collecting the user's password. The contents of this box should be hidden.
EditText	txtPassword2	A textbox for verifying the user's password. The contents of this box should be hidden.
EditText	txtEmail	A textbox for collecting the user's email address.
Spinner	txtGender	A combobox that contains {Male, Female, or Other}
Spinner	txtNameFirst	A textbox for collecting the user's first name.

Spinner	txtNameMiddle	An optional textbox for collecting the user's middle name.
Spinner	txtNameLast	A textbox for collecting the user's last name.
Spinner	txtBirthDay	A spinner for collecting the user's birthdate day.
Spinner	txtBirthMonth	A spinner for collecting the user's birthdate month.
Spinner	txtBirthYear	A spinner for collecting the user's birthdate year.
Button	btnRegister	A button that will attempt to create a new user account in the WVECG service. Upon failure, a Toast with an error message will be displayed. Upon success, the Register Activity will close and return to the Start Screen where the start screen will close and launch the Link ECG Activity.
Button	btnCancel	This button will return the user to the Login Screen.

Table 7.2.1.3 - Start Screen UI Components

7.2.1.4 ECG Screen

The ECG Screen is used by the user view and playback ECG sessions. It should be considered the Main Screen of the WVECG app. The ECG Activity may be started from the Link ECG Activity, or the Start Activity depending on the situation. The ECG Activity does not have a parent activity.

Type	ID	Description
ECGDisplay	ecg	The ECG display. This is a custom UI component to display a WVECG session on.
Action Bar Button	menuOptions	The button to launch the Settings Activity.
Action Bar Button	menuLoad	A button to replay a saved WVECG session.

Action Bar Button	menuRecord	A button to stop/stop recording a WVECG session.
Button	btnPlay	This button will start a previously recorded WVECG session or a currently active WVECG session.
Button	btnPause	This button will pause a previously recorded WVECG session or a currently active WVECG session.
Spinner	txtPatientSelector	If the authenticated user is a doctor, a combobox will appear with a list a patients that the doctor can select from. This allows the doctor to select what patients to load and save the WVECG sessions from. A doctor may select himself.

Table 7.2.1.4 - ECG Screen UI Components



Figure 7.2.1.4.1 Screenshot of the ECG Display Screen as seen by a doctor, an arrhythmia indicator is visible; additionally, a session is currently being recorded.

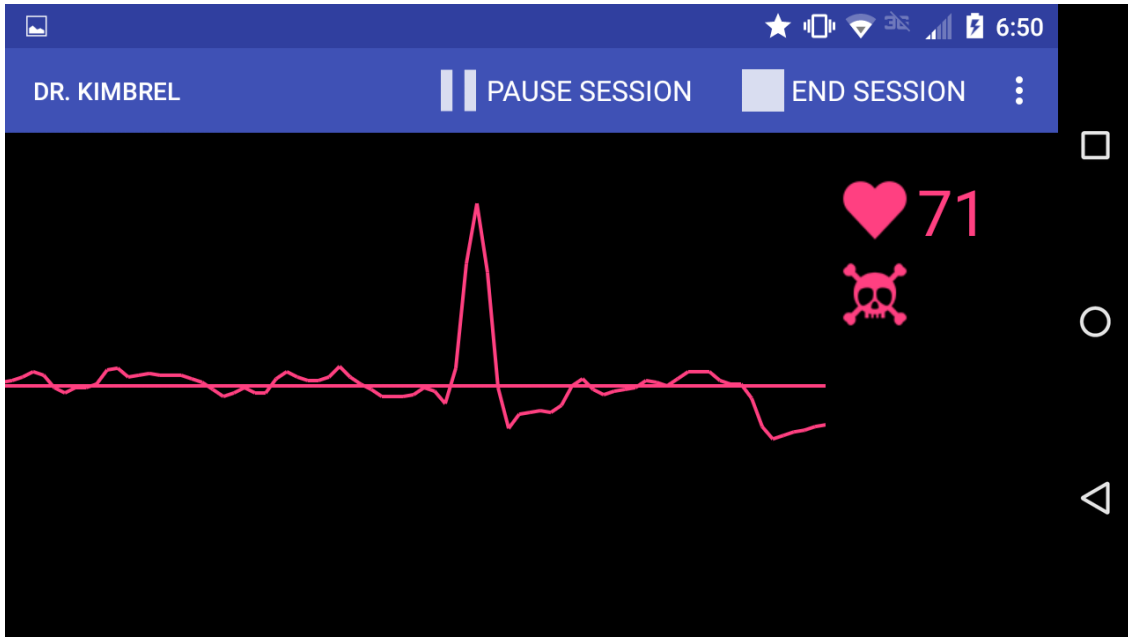

Figure 7.2.1.4.2 Screenshot of the ECG Display Screen as seen by a doctor, an arrhythmia indicator is visible; additionally, a session is currently being recorded.

7.2.1.5 Settings Screen

The Settings Screen is used by the user to set up certain aspects of the app. The Settings Activity is started from the ECG Activity. The Settings Activity's parent activity is the ECG Activity.

Type	ID	Description
List Item	itemLinkWWEKG	Will launch the Link WWEKG Activity.
List Item	itemLinkDoctor	Will launch the Link Doctor Dialog.

Table 7.3.1.5 - Settings Screen UI Components

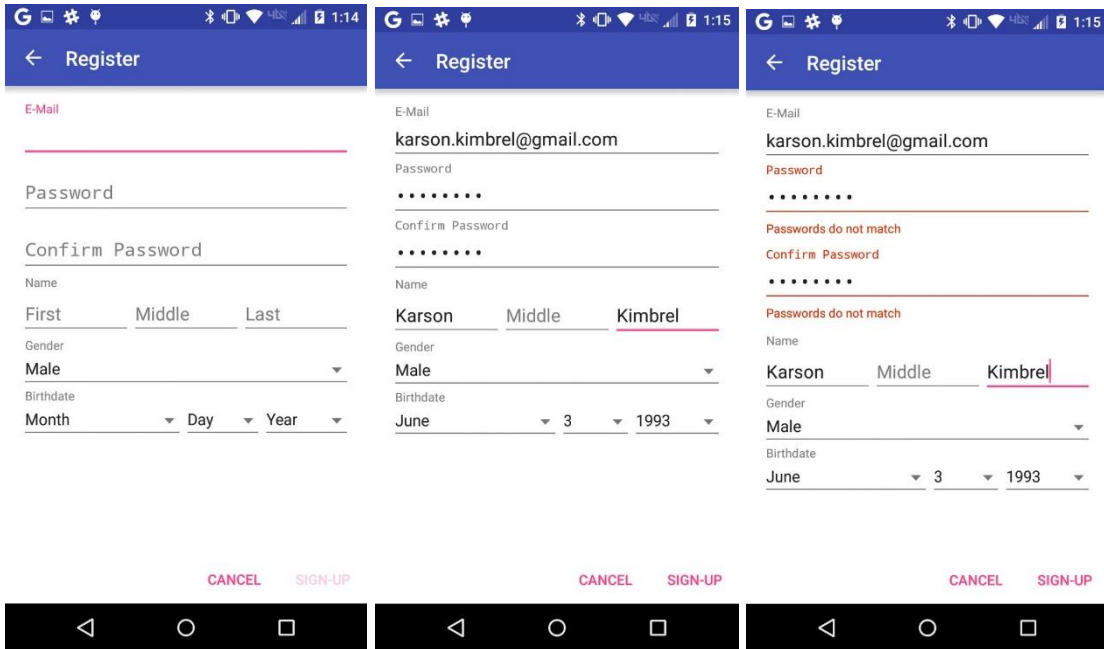

7.2.1.6 Link WVECG Screen

The Link WVECG Screen is used by the user to link the WVECG to the app. The Link WVECG Activity is started from the Settings Activity or the Start Activity depending on the situation. If the Link WVECG Activity was started by the Options activity, the Link WVECG's parent activity is the Options Activity; if it was launched by the Start Activity, it will not have a parent activity.

Type	ID	Description
ListView	list	List items contain the Bluetooth devices in the area. The items will contain the device MAC and the device name.

Table 7.2.1.6 - Link WVECG Screen UI Components

7.2.2 Custom UI Components

Any Android UI components (Views) that need to be made from scratch will be documented in this section.

7.2.2.1 EcgDisplay

The EcgDisplay view will be used to display both live sessions and previously recorded sessions stored on the WVECG Server. The display will include an

active ECG Graph, a section for metrics and warnings such as beats per minute or a warning for an abnormal heartbeat. The display will also be able to display highlights of the Q, R, and S peaks for easy human analysis of the ECG.

7.2.3 WVECG Bluetooth Link

The app will communicate with the WVECG Hub over Bluetooth LE. The app will use Android's internal libraries to communicate with the WVECG Hub. GATT IDs that the WVECG will use are as follows:

GATT Service	GATT Characteristic
00000777-0000-1000-8000-00805F9B34FB	0000FFE1-0000-1000-8000-00805F9B34FB

Table 7.2.3.1

When scanning for another WVECG device, the app will scan for Bluetooth LE devices that are advertising the GATT Service ID previously mentioned in **Table 7.2.3.1**. The defined GATT Characteristic will allow for the app to be notified when the characteristic changes. This will allow for a continuous stream of data from the WVECG Device.

Byte Number(s)	Description of Data
0	If the least significant bit of this byte is 1, then the WVECG Device is reporting that the user has an arrhythmia.
1	This byte is the heart rate that the WVECG Device is reporting.
2 and 3	These two bytes are the current amplitude of the ECG wave. Note when converting these 2 bytes into a short that byte 2 is less significant than byte 3.

Table 7.2.3.2

Bluetooth LE packets can be anywhere from 1 to 20 bytes long. Our characteristic will be sending packets that are strictly 4 bytes long. See **Table 7.2.3.2** for the full WVECG Bluetooth LE packet format.

7.2.4 WVECG Server Link

The app will communicate with the WVECG Service using the Application Programming Interface that is documented in Section 7. The app will use the `HTTPSConnection` class as a tool to easily make HTTPS calls to interface with the API. The server link will be implemented inside of the `WwecgAPI` class.

7.2.5 WWECG Live Processing

Live processing of WWECG sessions will be done. The app will analyze the data that is taken from the WWECG and look for certain metrics and features. Some of the features may not be included in the final product. Metrics and features must include: Beats per minute and highlighting of the Q, R, S peaks. Metrics and features may include the identification of atrial fibrillation and the identification of irregular heartbeat. If processing of certain metrics prove to be too intensive for the device, then these metrics and features may be processed on the WWECG server instead of the user's device, however, this is TBD.

7.2.6 WWECG Live Processing

Live processing of WWECG sessions will not be done on the WWECG app or the WWECG service. Instead the WWECG device will do all of the applicable signals processing. This will include the amplitude of the ECG waveform, heart rate and determining if the user/patient is having an arrhythmia.

7.2.7 Storage

WWECG sessions that are stored on the local device must either be kept in memory or be stored in the app's private data folder. Locally stored files must additionally be encrypted with an AES 256-bit key. This key is shared between the client and the server.

8 Administrative Information

The following sections below describe what methods that will be used throughout the development process. Featuring our project management methods, cost analysis, facilities, personal, current work completed and future WWECG milestones, these sections give an insight analysis of the project from a management rather than technical viewpoint.

8.1 Project Management Methodology

In order to stay organized throughout the development process, it was determined that the best way to keep the project on schedule as well as prepare group members for real world development lifecycles was to use an Agile-Scrum based project management platform. Using Google Sheets together with Scrum allowed the group to easily view the task needed to be completed at week as well as decrease procrastination.

8.2 Material Cost Analysis

The table below displays the estimated cost that will incur during the construction of the WVECG project.

Table 8.2.1 –Parts List

Part	Cost
Adafruit Resistor and Capacitor Book	\$39.95
SOIC-DIP adapter	\$10.00
4x Bluetooth HM-11 BLE modules	\$51.60
Adafruit5 V switching power supply for HUB	\$7.95
4x 150 mAh Li-ion Polymer batteries	\$23.80
2x USB Li-Ion charger modules	\$25.00
6x LM2663 Voltage converter	\$15.12
10x TL084 Quad JFET op amps	\$6.40
6x LM2621 Step up DC-DC converter	\$13.08
2x INA333 Instrumentation amplifier	\$9.00
2x TMS320 Digital signal processor	\$6.68
2x MCP4725	\$8.06
3xADC1251	\$33.42
2x MSP430F5438AIPZ	\$10.00
1x MSP432P401R	\$7.60
Estimated cost of PCB manufacturing	\$150.00
Total Parts Cost:	\$417.66

8.3 Facilities and Equipment

The development of the Wireless Wearable Electrocardiogram will primarily take place at the Electrical Engineering Senior Design Lab at the University of Central Florida. This location will provide breadboards and other electrical components useful for early design prototyping. Additionally, it will provide a housing location for the project so we do not have to transfer it back and forth often. The senior design lab also contains important lab equipment such as oscilloscopes, multimeters, function generators, and power supplies. Each of these pieces of equipment are key for testing and designing our project. Furthermore, this facility has a soldering location that will be employed to solder the surface mount components onto our printed circuit boards in the final design stages. Lastly, this location has key software that will be used to analyze and simulate circuits or

software to make sure the actual implementation of our devices behave as expected.

8.4 Personnel

Ulbert J. Botero

Major: Electrical Engineering

Minor: Computer Science

Design Contributions:

For the Wireless Wearable Electrocardiogram Ulbert Botero mainly focused on the signal processing and analog front end design. He designed the signal acquisition/conditioning circuit which consisted of 60Hz filtering, motion artifact filtering, and antialiasing filtering. Additionally, he assisted with the development of the overvoltage and overcurrent protection circuit to protect the electronics from possible defibrillator contact. Lastly, Ulbert implemented the signal processing algorithms to determine QRS complexes, heart rate, and warn of arrhythmias on the digital signal processor.

Alexander Consunji

Major: Computer Engineering

Design Contributions:

Alexander Consunji's role in the Wireless Wearable Electrocardiogram primarily focused on the communication between boards via Bluetooth and embedded systems programming. In addition, he had the job of interfacing the Analog-to-Digital and Digital-to-Analog converters with the embedded microcontrollers. Lastly, Alex designed the synchronization method to ensure the wireless wrist sensors sampled the biopotential signals at the same moments and transmitted them in unison.

Ryan Shifman

Major: Electrical Engineering

Design Contributions:

Ryan Shifman assisted with the development of the Analog Front End and defibrillator protection circuitry. His primary focus was power management of the wearable devices and the central Hub. This consisted of determining the charging method for the wrist sensors, the proper battery to employ for the hub and sensors, and how to power the Hub. Ryan was responsible for PCB layout design and soldering surface mount components along with circuit simulation and schematic capture.

Karson Kimbrel

Major: Computer Science

Design Contributions:

Karson Krimbrel's key contributions to the project consists in most of the dedicated software. In charge of all software design and implementation, Karson's expertise focus on the Android application and utilizing the operating system to connect with Bluetooth modules in the system. Karson is also heading the data storage and server design. Karson also have extensive experience with radio frequency transmissions and collaborates with other group members in dealing with possible wireless interference.

8.5 Past Activity Levels

Below lists a copy of the tasks that have been completed throughout Senior Design 1. This data was recorded using Google Sheets

Week	Main Item	Assigned To	In progress	Completed By	Date Completed	Results
9/6/2015						
	Initial Document- Divide and Conquer(Webcourses)			All	9/14/2015	Submitted online webcourses
			Alex	Alex	9/10/2015	
			Alex			
			Alex			
			All			
			Ryan and Joey	Ryan and Joey	9/10/2015	Completed See Divide and Conquer
	Attempt email Dr. Kapoor Again?					
	Meet with Optical Engineer?					
	Finalize Idea between BGM and ECG/EKG		All	All	9/10/2015	Finalized were going with ECG/EKG wireless implementation

	Email Heinrich for possible CS group member		Ryan	Ryan		Finish proposal and submit it to webcourses
	Email Richie about new group member		Ryan	Ryan		Tell Richie we no longer need optical engineer
	9/12/15 -- Sponsorship meeting		Ryan and Alex	Ryan and Alex	9/12/2015	
	TI analog design contest form (worth a shot)		Joey	Joey	9/12/2015	Researched by joey will compete
	Seartech A.I. form (maybe)		All	All	9/12/2015	No longer going to submit proposal
	More research found		Joey	Joey		
9/13/2015						
	Email Heinrich or the kid about our new member is he with us or not	Ryan	Ryan	Ryan	9/14/2015	Karson is now a group member
	Read all source materials we haven't	Ryan and Alex	Ryan	Ryan	9/17/2015	Still have more documents to read
	Submit Proposal to Philips	All				
	Order electrodes to do early testing for design considerations	All	Alex	Alex	9/17/2015	Items arrive on Saturday 9/18
	Test electrode signal acquisition stage on breadboard	All				

	Analog Audio to Digital Bluetooth signals research	All	All	All	9/17/2015	No longer an option not feasible
	Meeting with Dr. Richie to discuss feasibility of the project	All	All	All	9/16/2015	Met with him and project was approved redo submission
	Redo design and submit proposal to Phillips and other companies	All				
			All			
			All	All	9/17/2015	
9/20/2015						
	Finish redoing block diagram	All	All	All	9/24/2015	New block diagram is now done along with revised divide and con
	Resubmit finalized design and conquer to Richie and submit to Philips	All	All		9/24/2015	
	Decide on parts we want to order and design aspects the add them to part list	All	All		Next Week	
	Create list of HIPAA limitations	All	Karson	Karson	10/1/2015	
	Email Richie with new proposal and documents	All	Alex	Alex	9/25/2015	
9/27/2015						

	Parts List Actually get Done	All				
	O-Scope Functionally Reading Example	All	All	Ryan and Joey	10/29/2015	
	Design considerations	All	All	All	10/9/2015	
	Encryption and Wireless Security	All	Karson	Karson	10/1/2015	
	Table Of Contents for Final Report	All	All	All	10/14/2015	
10/5/2015						
	Carry over tasks from previous week	All				
	Make a more formal request for Philips and Mark	All	Alex	Alex	10/9/2015	
10/12/2015						
	Paper Section Assignments	All	All	All	10/15/2015	
	Finish Design	All	All	All	10/19/2015	
	Electrode Sampling	All	All	All	10/29/2015	
10/19/2015						
	Start writing pages 60 pages due by the 11/12 rough draft	All				
	Design Considerations and Documentation	All				

	TI Competition Documents	All	All	All	10/29/2015	
	Parts Orders? Instrumentation Amplifier	Joey				
10/26/2015						
	Carry over all tasks from previous weeks					
11/1/2015	Continue Carry over	All	All	All		
	Order Op Amps, Instrumentation Amp, Decide on MCU	All	All	All	11/8/2015	
	Test and Use HM-11	Alex	Alex	Alex		
	Test A/D	All	All	All	11/8/2015	
11/8/2015	Finish Rough Draft	All	All	All	11/11/2015	
11/15/2015	Write for final Draft					
11/22/2015	Continue Writing					
11/29/2015	Continue Writing					
12/6/2015	Edit Writing	All	All	All	12/5/2015	
	Professionally Bind and Submit Final Report	All	All	All	12/9/2015	

8.6 Future Milestone Chart

Week 1:

Hardware:

- Prototype Analog Front End for each sensor and test.
- Start mocking up a printed circuit board in eagle for wristbands.
- Test data being sent across devices between Bluetooth on test microcontrollers

Software:

- The LAMP stack and security certificate should be installed on the server.
- Begin embedded software design for the hub to broadcast and timestamp.

Week 2:

Hardware:

- Continue to condition signal. Compare accuracy of AFE sensor to traditional ECG using ECG signal simulator, test Analog-to-Digital conversion.
- Test Bluetooth transmission with multiple slaves from a single master and prototype Hub.
- Start mocking up a printed circuit board in eagle for the hub. Verify power conditions and increase battery capacity if necessary.

Software:

- Create the MySQL tables. Start work on the /auth/ section of the server endpoints.
- Begin testing sending two times consistently to two separate serial test devices with the same timestamp

Week 3:

Hardware:

- Have Bluetooth transmission successful, Digital-to-Analog Conversion accurate, and compare final result after Instrumentation Amplifier.
- Test Charging and housing of sensors at Hub.

Software:

- All /users/, /data/, and /auth/ endpoints should be finished.

Week 4:

Hardware:

-Fabricate PCB for wrist sensors and HUB by uploading eagle designs to Osh Park.

Software:

-The /ecg/ section of server endpoints should be finished (with the exception of the /auth/upload post processing of files).

-Complete software for hub transmitting startup items via serial

Week 5:

Hardware:

-Begin soldering surface mount parts to the printed circuit boards

-Manufacture enclosures for wrist sensors and Hub PCBs.

Software:

Implement Signal Processing Algorithms on DSP.

-The start, login, and register screens of the app should be finished

Week 6:

Hardware:

-PCBs should be completed and components soldered for sensors and Hub.

Software:

-Test Signal Processing Algorithms.

-The Link WVECG Screen and the ECG Screen should be started.

Week 7:

Hardware:

-Hardware should be completed.

Software:

-Test communication with mobile application, and transmission of key information from signal processing algorithms.

-The Settings Screen and the Link Doctor Screen should be finished.

Week 8:

Hardware: Complete

Software:

- Test mobile application display of information and database.
- Link WVECG Screen and the ECG Screen should be finished.

Week 9:

Hardware:

- Test Complete System, determine any improvements that can be made to final design in a timely manner, add another sensor if possible.

Software:

- Test Complete System, determine any improvements that can be made to final design in a timely manner.

Week 10:

Present Final Product.

9 Construction and Testing

The following subsections review how the project integrates and will be tested in order to meet all standards and requirements.

9.1 Chipset Integration

The cost of parts differs depending on package size, for prototyping it is more cost efficient to purchase or obtain free samples from Texas Instruments in a SOIC pin package than a DIP package. For this reason many of the parts used in testing were SOIC package components soldered onto a SOIC-DIP adaptor board. The op amps used in the signal acquisition stage were reused from previous labs and were fortunate enough to be DIP components.

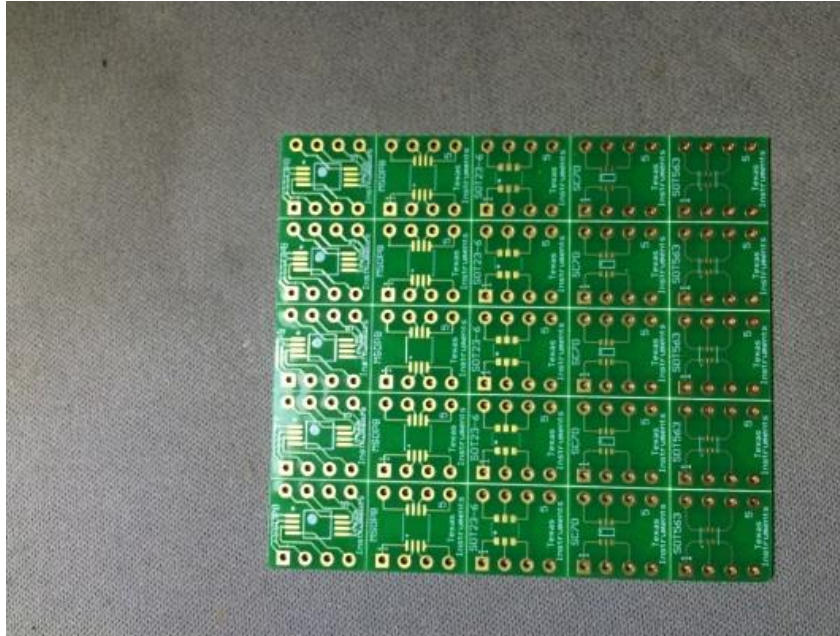

Figure 9.1 – SOIC to DIP adapter

9.2 PCB Design

Eagle PCB by Cadsoft will be used as the primary software for printed circuit board layout.

9.3 PCB Manufacturing

The printed circuit boards for the WWECG will be manufactured by OSH Park using the PCB design layout uploaded to their website. Osh Park is the most cost efficient for this particular design. Osh Park's standard 2 layer printed circuit board starts at \$5.00 per square inch and comes with three copies. Having three copies of a circuit board is beneficial in reducing costs in that both wristbands will incorporate the same exact PCB.

Components will be either reused from the prototyping phase or will be ordered through Texas Instruments, Digi-key, Adafruit or Mouser depending on surface mount part availability. It is more cost efficient to purchase a surface mount resistor kit and capacitor kit that provide various values and order separately if the kits do not provide all values needed.

The final design will be hand soldered using a PACE Worldwide adjustable temperature soldering machine in an electrostatic discharge (ESD) safe environment on top of an ESD mat provided by the place of employment of one of the design team members. The benefit of using an adjustable temperature

soldering machine is that some components list different soldering temperatures and contact times as they may be delicate.

9.4 ECG Signal Quality

The quality of the signal obtained should be accurate and comparable to standard ECG signals. For this reason the design of the WVECG has been centered on reducing as much outside noise as possible.

9.5 Level of Comfort

One of the primary concerns at the conception of the WVECG was the comfort and portability of the design. The intention was to design a functional ECG that optimized portability without compromising comfort levels for the user. For this reason the design was based on reducing size and weight of components so the research stage was important in finding low power components that would reduce the amount of power used with each diagnosis thus reducing the size of the battery packs needed to power the components. Figure 9.5 exhibits the size of ICs used compared to a US quarter.

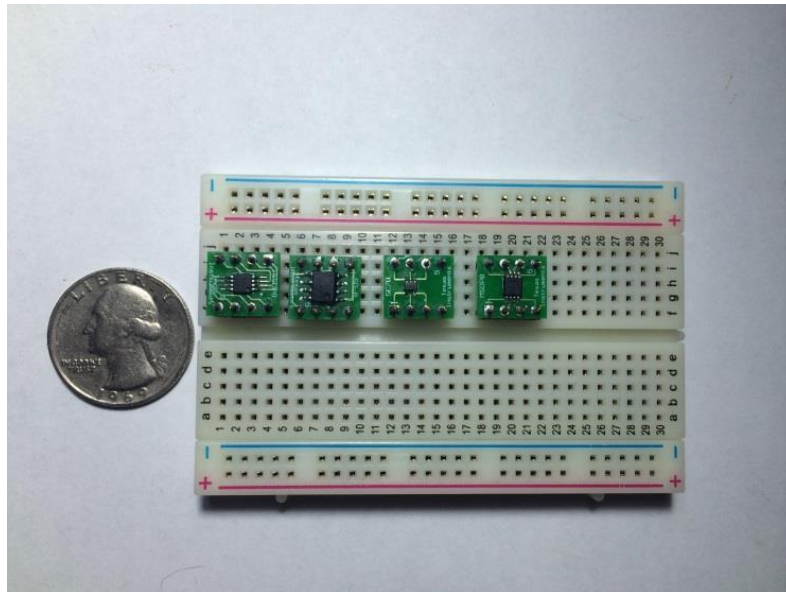

Figure 9.5 – Size comparison of SOIC chips on DIP adapter board

9.6 Testing Procedures

Overall testing throughout the projects implementation phase will be done by using a unit testing format for both software and hardware integration. The choice to use

unit testing stems from the ease with which debugging will be done. For software testing proper unit tests provide a simpler viewpoint when searching for bugs that may have occurred within different levels. Hardware also benefits from unit testing in regards to its ability to isolate issues that occur within the boards and their parts.

9.6.1 Hardware Testing

Testing of the sensors was done using a breadboard so DIP components were favored for their convenience. **Figure 9.6.1** shows the prototype signal acquisition stage of two sensors on a breadboard

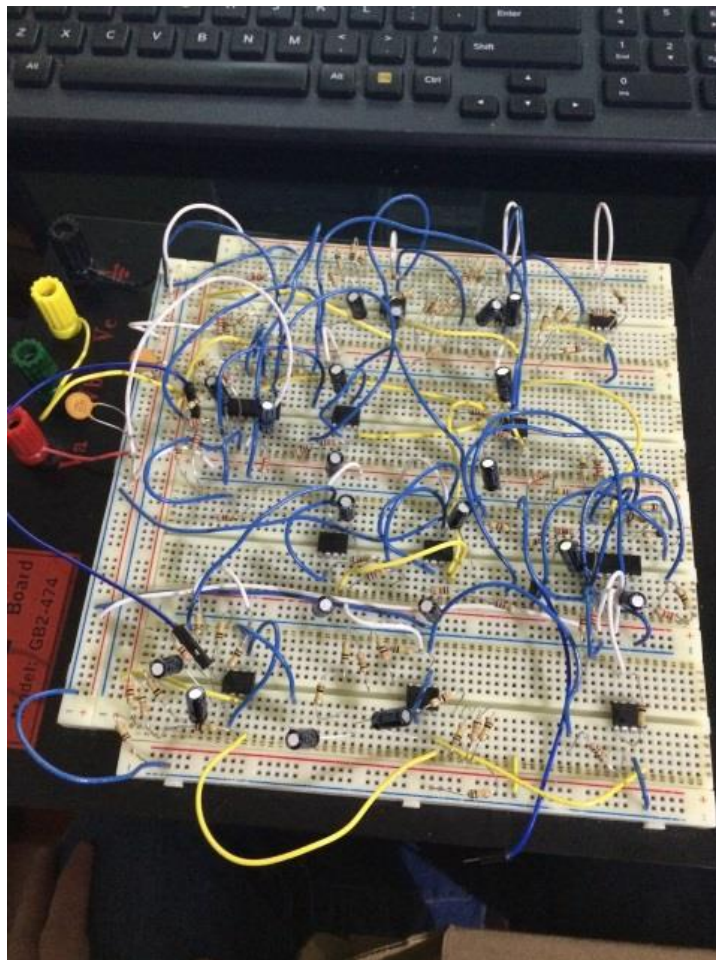

Figure 9.6.1 – Breadboard Sensors

9.6.2 Software Testing

For the software testing the current development is based on test driven code since it allows for an easier unit test model. Using test-driven code design also provides

an easier manner in which to confirm that the code meets requirements since it allows for each section of code to be tested and confirmed to requirements throughout its development.

10 Conclusion

Throughout the research and design portion of this course we learned copious amounts of information. This information ranged from common portable device power management techniques, conventional electrocardiogram implementations, different types of data converters, and different signal processing implementation methods. After gathering all this research we then devised what we felt was the best plan of attack to make a completely wireless wearable electrocardiogram sensing device. There were many considerations that were taken in choosing our device. We began the project with the goal of making an accurate, comfortable, and portable device. Therefore, our design had to include small scale, low power electronics to maintain portability and comfort. Additionally, in order to maintain accuracy we used high accuracy data converters with extensive front end analog signal processing. Another issue we had to consider was developing this product at a reasonable price. Since we do not have a sponsor at the moment we mainly focused on using Texas Instruments products due to their affordability for our budget range while still maintaining high accuracy and fidelity. This project was a great exercise in putting all the theory learned in the classroom throughout our undergraduate curriculum into practice to design a final product. The next step will be to build a functional prototype of our design and adjust to any problems that could arise from possible design issues we may have overlooked. If we are fortunate enough to not run into any such issues the next logical step will naturally be to improve it. Even when the initial design is produced an engineer's job is never truly done.

11 APPENDIX A- Copyright Permission

Permission of use

Nicholas Patchett MD.

March 27th 2015

The author of this work does not endorse me or the use of my work.

[Licensing](#) [[edit](#)]

I, the copyright holder of this work, hereby publish it under the following license:

This file is licensed under the [Creative Commons Attribution-Share Alike 4.0 International](#) license.

You are free:

- **to share** – to copy, distribute and transmit the work
- **to remix** – to adapt the work

Under the following conditions:

- **attribution** – You must attribute the work in the manner specified by the author or licensor (but not in any way that suggests that they endorse you or your use of the work).
- **share alike** – If you alter, transform, or build upon this work, you may distribute the resulting work only under the same or similar license to this one.



12 APPENDIX B- References

Riggs, T., B. Isenstein, and C. Thomas. "Result Filters." *National Center for Biotechnology Information*. U.S. National Library of Medicine, n.d. Web. 05 Nov. 2015.

Narayanaswamy, S. "High Resolution Electrocardiography." *Indian Pacing and Electrophysiology Journal*. Indian Pacing and Electrophysiology Group, 1 Apr. 2002. Web. 06 Nov. 2015.

Winter, Bruce B., and John G. Webster. "Driven-right-leg Circuit Design." *IEEE Transactions on Biomedical Engineering IEEE Trans. Biomed. Eng.* BME-30.1 (1983): 62-66. Web.

Texas Instruments. *Improving Common-Mode Rejection Using the Right-Leg Drive Amplifier, Sbaa188 - TI.com. Improving Common-Mode Rejection Using the Right-Leg Drive Amplifier, Sbaa188 - TI.com*. Texas Instruments, n.d. Web. 09 Nov. 2015.

Pan, Jiapu, and Willis J. Tompkins. "A Real-Time QRS Detection Algorithm." *IEEE Transactions on Biomedical Engineering IEEE Trans. Biomed. Eng.* BME-32.3 (1985): 230-36. Web.

Gari Clifford, John Fisher, Julie Greenberg, and William Wells. *HST.582J Biomedical Signal and Image Processing, Spring 2007*. (Massachusetts Institute of Technology: MIT OpenCourseWare), <http://ocw.mit.edu> (Accessed 9 Dec, 2015). License: Creative Commons BY-NC-SA

Laumeister, Bill. "Lightning Bolts, Defibrillators, And Protection Circuitry Save Lives." *Lightning Bolts, Defibrillators, And Protection Circuitry Save Lives*. N.p., n.d. Web. 30 Nov. 2015.

Krois, I., V. Isgum, and M. Cifrek. "The Amplifier Input Protection Circuit for a Intraoperative Evoked Potential Monitoring System." *Proceedings of the 12th*

IEEE Mediterranean Electrotechnical Conference (IEEE Cat. No.04CH37521) (2004): n. pag. Web.

Yanowitz, Frank G., MD. "3. Characteristics of the Normal ECG." *ECG Learning Center*. University of Utah School of Medicine, n.d. Web. 25 Nov. 2015.

Ventricular Tachycardia. Ventricular Tachycardia. Blausen Medical, n.d. Web. 3 Dec. 2015.

Zevitz, Michael E., MD. "Ventricular Fibrillation." : *Background, Pathophysiology, Etiology*. Medscape, n.d. Web. 5 Dec. 2015.

"Ventricular Fibrillation: MedlinePlus Medical Encyclopedia." *U.S National Library of Medicine*. U.S. National Library of Medicine, n.d. Web. 02 Dec. 2015.

Thies, Karl-Christian, Karin Boos, Kai Müller-Deile, Wolfgang Ohrdorf, Thomas Beushausen, and Peter Townsend. "Ventricular Flutter in a Neonate—severe Electrolyte Imbalance Caused by Urinary Tract Infection in the Presence of Urinary Tract Malformation." *The Journal of Emergency Medicine* 18.1 (2000): 47-50. Web.

"Atrial Flutter Information - The Mount Sinai Hospital." *The Mount Sinai Hospital*. N.p., n.d. Web. 3 Dec. 2015.

Searle, A., and L. Kirkup. "A Direct Comparison of Wet, Dry and Insulating Bioelectric Recording Electrodes." *Physiol. Meas. Physiological Measurement* 21.2 (2000): 271-83. Web.

Oweis, Rami J., and Basim O. Al-Tabbaa. "QRS Detection and Heart Rate Variability Analysis: A Survey." *Biomedical Science and Engineering* 2.1 (2014): 13-34.

"ADC and DAC." *The Scientist and Engineer's Guide to Digital Signal Processing*. Place of Publication Not Identified: Stationery Office, 2006. 35-66. Print.

"ADI - Analog Dialogue | Data Conversion Handbook." *ADI - Analog Dialogue | Data Conversion Handbook*. N.p., n.d. Web. 28 Nov. 2015.

Bluetooth Special Interest Group "Bluetooth Low Energy Regulatory Aspects", April 2011

Smart Wearable ECG EKG Monitor - QardioCore. (n.d.). Retrieved October 9, 2015, from <https://www.getqardio.com/qardiocore-wearable-ecg-ekg-monitor-iphone/>

Delano, Maggie K.; Sodini, Charles G., "A long-term wearable electrocardiogram measurement system," in *Body Sensor Networks (BSN), 2013 IEEE International*

Conference on , vol., no., pp.1-6, 6-9 May 2013

URL: <http://ieeexplore.ieee.org/stamp/stamp.jsp?tp=&arnumber=6575459&isnumber=6575455>

Difference between Bluetooth and Zigbee Technologies. (n.d.). Retrieved December 9, 2015, from <http://www.engineersgarage.com/contribution/zigbee-vs-bluetooth>

The Nuremberg Code. (n.d.). Retrieved December 9, 2015, from <http://www.hhs.gov/ohrp/archive/nurcode.html>

Retrieved December 9, 2015, from https://www.students.graduate.ucf.edu/policy/human_subjects_research/

The OAuth 2.0 Authentication Framework <https://tools.ietf.org/html/rfc6749>

13 APPENDIX C- Data Sheets and User Guides

DSP TMS320C5535: <http://www.ti.com/product/TMS320C5535/datasheet>

ADC ADS1251: <http://www.ti.com/lit/ds/sbas184d/sbas184d.pdf>

DAC MCP4725: <http://www.ti.com/product/MCP4725/datasheet>

Instrum. INA333: <http://www.ti.com/lit/ds/symlink/ina333.pdf>

MCU MSP430F5438: <https://www.ti.com/product/MSP430F5438A/datasheet>

MCU MSP430F5438: <https://www.ti.com/product/MSP432P401R/datasheet>

HM-11 BLE Module: http://www.seeedstudio.com/wiki/Bluetooth_V4.0_HM-11_BLE_Module

TI CC2541: <http://www.ti.com/lit/ds/symlink/cc2541.pdf>